

DATASHEET

TRAFFIC MANAGEMENT ACCESSORY

SDLC MODULE

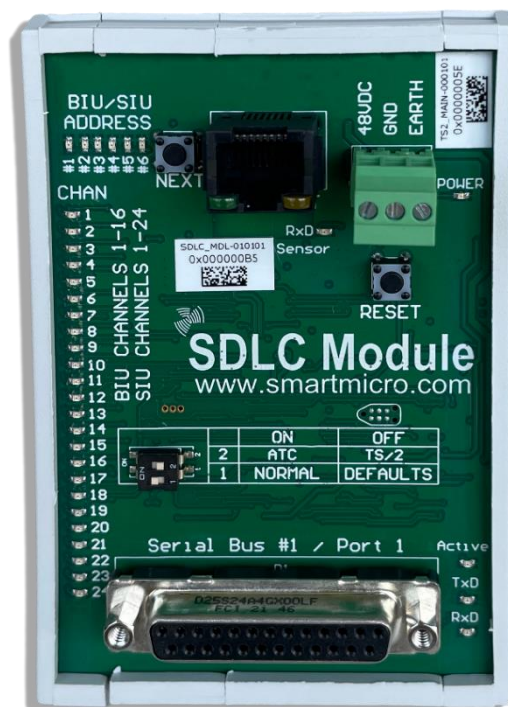

s.m.s, smart microwave sensors GmbH
In den Waashainen 1
38108 Braunschweig
Germany

Phone: +49 531 39023-0
Fax: +49 531 39023-599
info@smartmicro.de
www.smartmicro.com

CONTENT

- 1 User Safety Warning..... 3
- 2 Product Specification 4
 - 2.1 Features and Applications 4
 - 2.2 SDLC Module Specifications..... 4
 - 2.3 Board Description and General Functions 5
 - 2.4 Dimension 6
 - 2.5 SDLC Port and Connectors 7
 - 2.6 Typical Multi-Sensor Connection with COM HUB 8
 - 2.7 Typical Multi-Sensor Connection with TMIB2..... 9
- 3 Compliances..... 9
- 4 Legal Disclaimer Notice 10

1 USER SAFETY WARNING

Please read the entire document carefully before using the device.

INSTALLATION

Please pay attention to the details below before installing and connecting the device:

- Only use provided or approved equipment for the operation.
- Only skilled and instructed persons shall install and connect the device.
- All connectors are pin-coded and fit in only one position.
- Be cautious when using the device on or around active roadways and pay attention to moving traffic.
- Make sure that test procedures are in accordance with local safety policies and procedures as well as company practices.

OPERATION

Using an SDLC Module does not influence the sensor performance.

Please note that the device is not waterproof. Take care of proper rain coverage when working outside. Do not operate the device if the device itself or any cables are damaged.

Do not dispose electrical and electronic equipment in household trash.

TECHNICAL SERVICE



Only use provided or approved equipment for operation.

Do not attempt to service or repair this device:

- No user-maintainable parts are contained in the device.
- To avoid electrical shock, do not remove or open the cover.
- Unauthorized opening will void all warranties.
- smartmicro is not liable for any damages or harms caused by unauthorized attempts to open or repair the device.

2 PRODUCT SPECIFICATION

The smartmicro SDLC Module collects 64 outputs generated by all connected sensors and transfers them to the controller via SDLC protocol.

2.1 FEATURES AND APPLICATIONS

The SDLC Module has the following features:

- Support of both TS/2(BIU) and ATC (SIU) emulation
- Emulation of 1,2,3 or 4 BIU addresses, 16 inputs/addresses
- Emulation of 1 SIU address, 54 inputs and additional 4 pedestrian inputs
- LEDs for up to 24 channels per BIU/SIU
- LEDs for communication activities
- Housing with holder for DIN rail
- Ethernet sensor communication
- Configuration via Traffic Web UI over Ethernet

2.2 SDLC MODULE SPECIFICATIONS

Operating temperature	-34...+74°C -29...+165°F
Vibration	0.015 in DA (Nema TS2-Standards)
Shock	10 g (Nema TS2-Standards)
Power consumption at 25°C 77°F	1.2 Watt
Operating voltage	10...48 V

Table 1: SDLC specifications

2.3 BOARD DESCRIPTION AND GENERAL FUNCTIONS

Serial Bus port – TS/2, ATC, please see

1. Table 2 : Pinout of the DB25 port 1
2. Ethernet port Default IP address is 192.168.11.3
3. Green Ethernet LED – The Link LED lights up when the device is connected to Ethernet.
4. Yellow Ethernet LED – The data LED lights up when the device is communicating over Ethernet.
5. TS/2-ATC DIP switch – After changing DIP switch reset or power cycle for change.
6. Next button – Press Next to display the next input status/address.
7. ACTIVE LED – It is controlled by output 54 for ATC only. In other cases, it is not used. It will switch off after 2 seconds of non-communications.
8. TxD – TxD flashes when the SDLC Module responds to a frame.
9. RxD – RxD flashes when a valid SDLC frame is received at the configured address or at the broadcast address. The typical time of broadcast is once per second.
10. RxD Sensor – RxD Sensor flashes only when an HTTP GET command is sent to set the inputs.
11. Power 10-48V (DC) with Power LED.
12. Reset button – hold reset for 2 seconds to show Device-ID, firmware version. After release the device will restart when all LEDs light up.

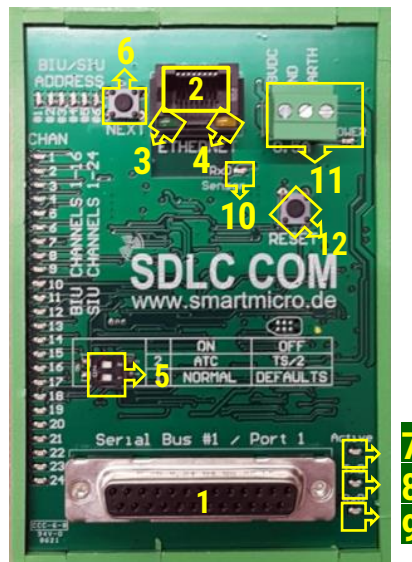

2.4 DIMENSION

All values are given in mm.

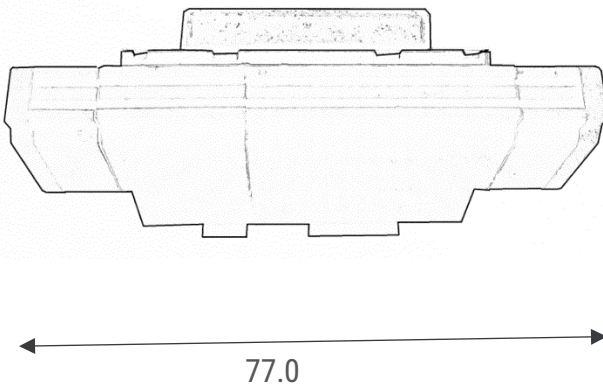
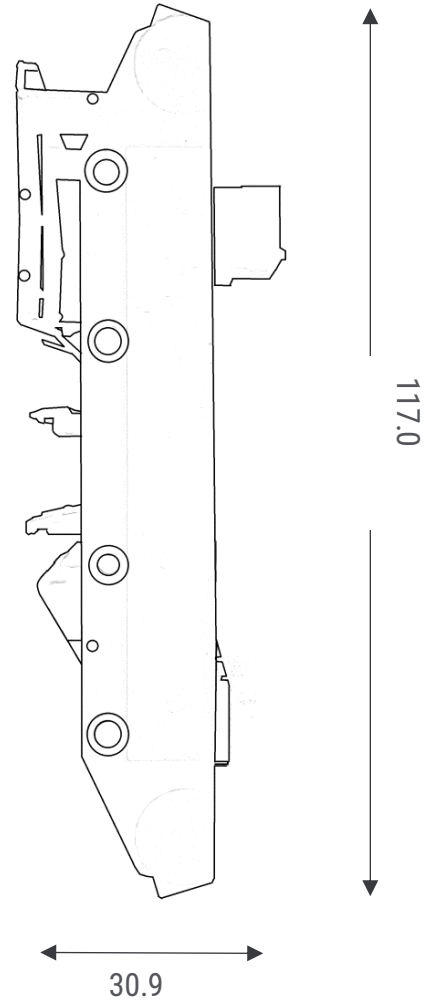
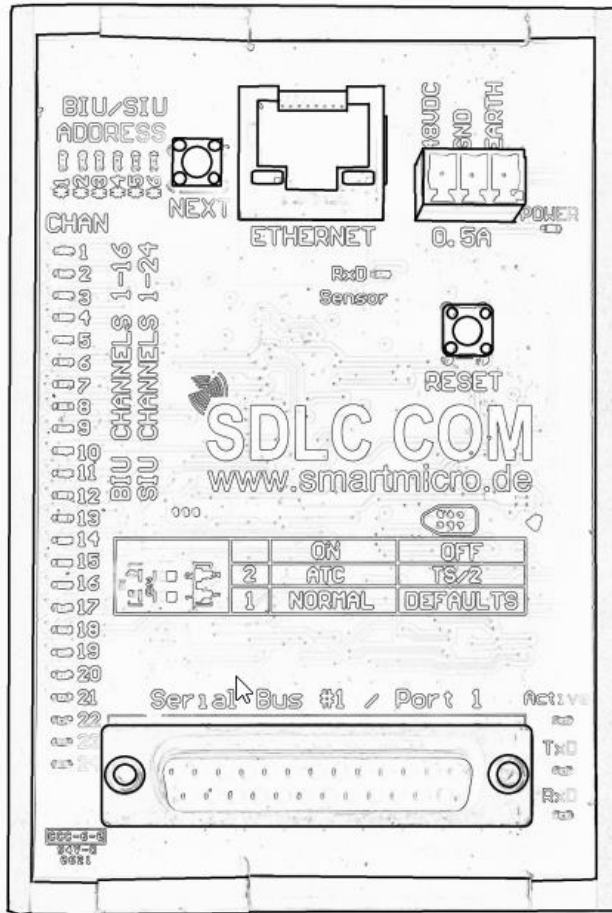

2.5 SDLC PORT AND CONNECTORS

SDLC Module Signals DB25	DIR	SDLC Module DB25 SB#1/Port 1 ATC/TS2	TS/2 DB15 Port 1	2070 TEES TS/2 DB25 SP3
RxD+	IN	1	1	5
RxC+	IN	3	3	7
TxD+	OUT	2	5	6
TxC+	OUT	4	7	8
RxD-	IN	14	9	18
RxC-	IN	16	11	20
TxD-	OUT	15	13	19
TxC-	OUT	17	15	21

Table 2 : Pinout of the DB25 port 1

2.6 TYPICAL MULTI-SENSOR CONNECTION WITH COM HUB

The following figure shows how an SDLC Module can be connected to a COM HUB. The SDLC Module must be connected to ETH2. The cable between SDLC Module and COM HUB is a standard ethernet cable.

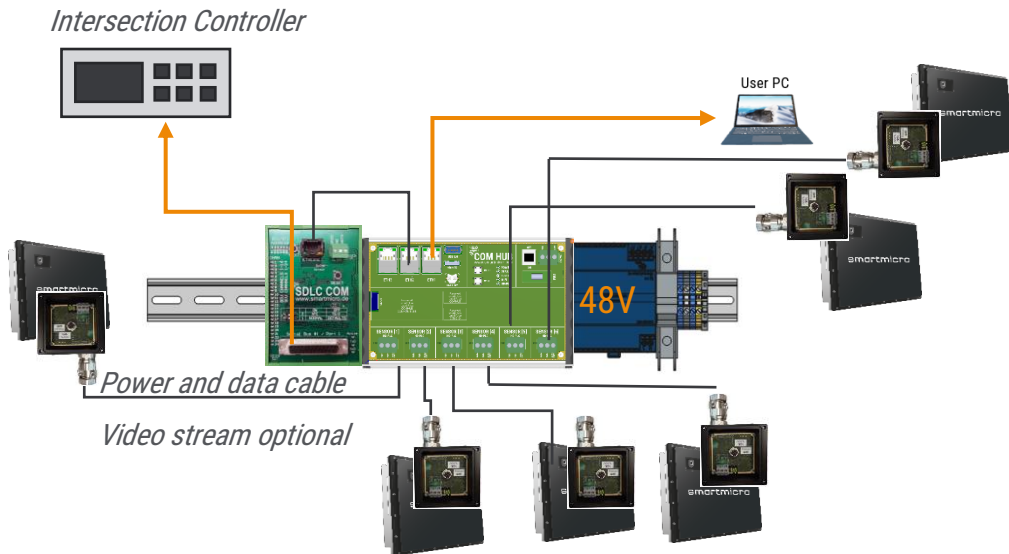

Figure 2-1 Connecting six smartmicro sensors to a controller through the COM HUB and SDLC Module

2.7 TYPICAL MULTI-SENSOR CONNECTION WITH TMIB2

The following figure shows how an SDLC Module can be connected to a TMIBv2. The connection between sensors and TMIB2 is RS485

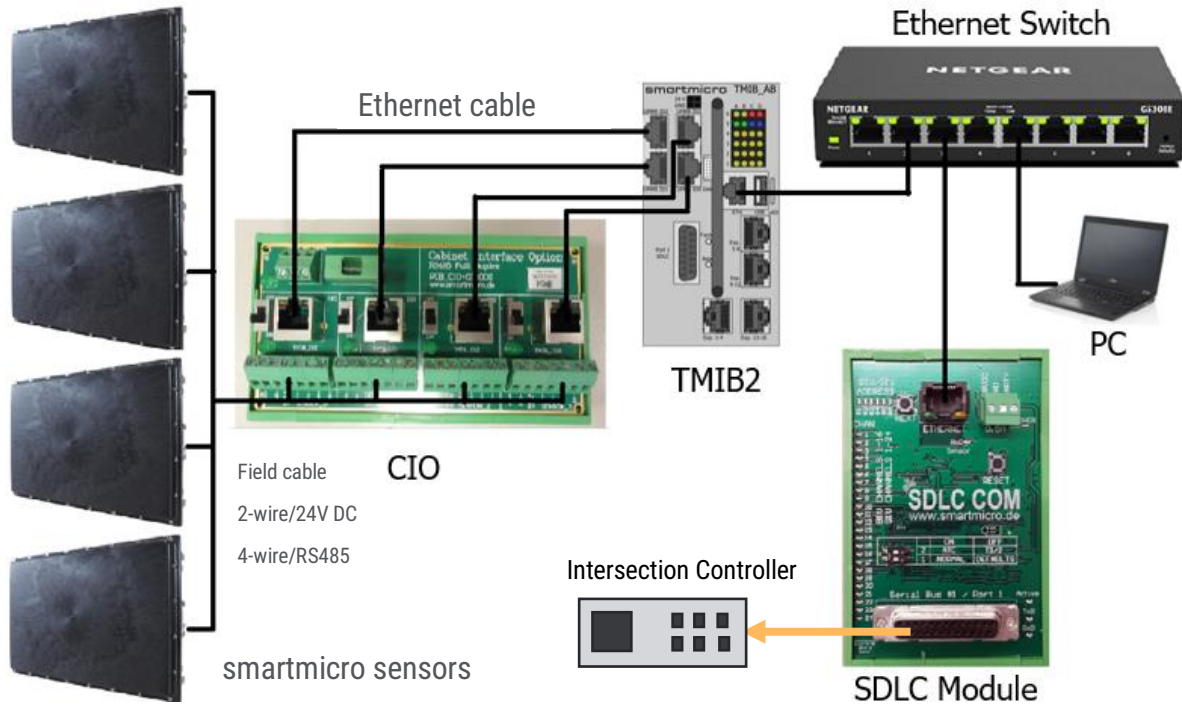

Figure 2-2 Connection with four sensors and TMIB2

3 COMPLIANCES

With regard to operating conditions like temperature, vibration etc., the SDLC module was tested and certified by independent test labs to comply with:

- NEMA TS-2-2021

4 LEGAL DISCLAIMER NOTICE

All products, product specifications and data in this document may be subject to change without notice to improve reliability, function or otherwise.

Not all products and/or product features may be available in all countries and regions. For legal reasons features may be deleted from products or smartmicro may refuse to offer products. Statements, technical information and recommendations contained herein are believed to be accurate as of the stated date. smartmicro disclaims any and all liability for any errors, inaccuracies or incompleteness contained in this document or in any other disclosure relating to the product.

To the extent permitted by applicable law, smartmicro disclaims (i) any and all liability arising out of the application or use of the product or the data contained herein, (ii) any and all liability of damages exceeding direct damages, including - without limitation - indirect, consequential or incidental damages, and (iii) any and all implied warranties, including warranties of the suitability of the product for particular purposes.

Statements regarding the suitability of products for certain types of applications are based on smartmicro's knowledge of typical requirements that are often placed on smartmicro products in generic/general applications. Statements about the suitability of products for a particular/specific application, however, are not binding. It is the customer's/user's responsibility to validate that the product with the specifications described is suitable for use in the particular/specific application. Parameters and the performance of products may deviate from statements made herein due to particular/specific applications and/or surroundings. Therefore, it is important that the customer/user has thoroughly tested the products and has understood the performance and limitations of the products before installing them for final applications or before their commercialization. Although products are well optimized to be used for the intended applications stated, it must also be understood by the customer/user that the detection probability may not be 100% and that the false alarm rate may not be zero.

The information provided, relates only to the specifically designated product and may not be applicable when the product is used in combination with other materials or in any process not defined herein. All operating parameters, including typical parameters, must be validated for each application by the customer's/user's technical experts. Customers using or selling smartmicro products for use in an application which is not expressly indicated do so at their own risk.

This document does not expand or otherwise modify smartmicro's terms and conditions of purchase, including but not being limited to the warranty. Except as expressly indicated in writing by smartmicro, the products are not designed for use in medical, life-saving or life-sustaining applications or for any other application in which the failure of the product could result in personal injury or death.

No license, expressed or implied, by estoppel or otherwise, to any intellectual property rights is granted by this document or by any conduct of smartmicro. Product names and markings noted herein may be trademarks of their respective owners.

Please note that the application of the product may be subject to standards or other regulations that may vary from country to country. smartmicro does not guarantee that the use of products in the applications described herein will comply with such regulations in any country. It is the customer's/user's responsibility to ensure that the use and incorporation of products comply with regulatory requirements of their markets.

If any provision of this disclaimer is, or is found to be, void or unenforceable under applicable law, it will not affect the validity or enforceability of the other provisions of this disclaimer.