

DATASHEET

TRAFFIC MANAGEMENT ACCESSORY

Cabinet Relay Option (CRO)

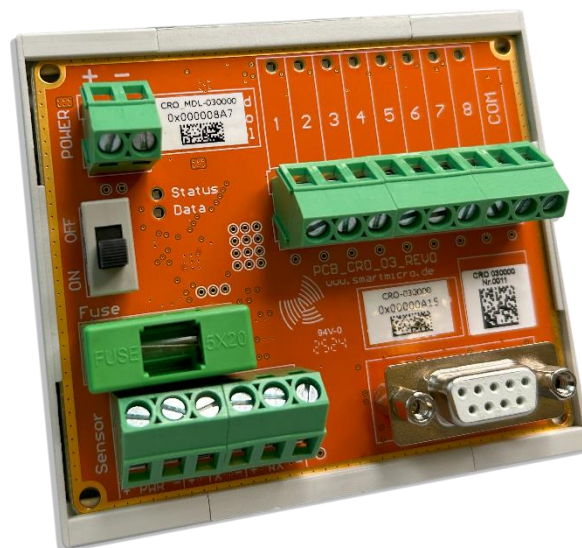

s.m.s, smart microwave sensors GmbH
In den Waashainen 1
38108 Braunschweig
Germany

Phone: +49 531 39023-0
Fax: +49 531 39023-599
info@smartmicro.de
www.smartmicro.com

CONTENT

1	USER SAFETY WARNING	3
2	PRODUCT SPECIFICATIONS	4
2.1	FEATURES AND APPLICATIONS	4
2.2	SYSTEM LAYOUT	5
2.3	SOFTWARE CONFIGURATION	6
2.4	PRODUCT DIMENSIONS	7
2.5	PRODUCT CONNECTORS	8
2.6	WIRING DIAGRAMM	9
3	CHARACTERISTICS.....	11
4	COMPLIANCES.....	12
5	LEGAL DISCLAIMER NOTICE	13

1 USER SAFETY WARNING

Please read the entire document carefully before using the device.

INSTALLATION

Please pay attention to the details below before installing and connecting the device:

- Only use provided or approved equipment for the operation.
- Only skilled and instructed people shall install and connect the device.
- Be cautious when using the device on or around active roadways and pay attention to moving traffic.
- Make sure that test procedures are in accordance with local safety policies and procedures as well as company practices.

OPERATION

Using a Cabinet Relay Option (CRO) does not influence the sensor performance.

Please note that the device is not waterproof. Take care of proper rain coverage when working outside. Do not operate the device if the device itself or any cables are damaged.



Do not dispose electrical and electronic equipment in household trash.

TECHNICAL SERVICE

Only use provided or approved equipment for operation.

Do not attempt to service or repair this device:

- No user-maintainable parts are contained in the device.
- To avoid electrical shock, do not remove or open the cover.
- Unauthorized opening will void all warranties.
- smartmicro is not liable for any damages or harms caused by unauthorized attempts to open or repair the device.

2 PRODUCT SPECIFICATIONS

The smartmicro Cabinet Relay Option (CRO) is a hardware module that extends a smartmicro radar sensor by eight hardware relays via the standard RS485 communication interface.

It is suitable for the following traffic management sensors:

- TOPGRD Family
- UMRR-12 Family
 - o TRUGRD Stream
 - o TRUGRD
 - o TRUGRD Lite
 - o TRUGRD LR
- UMRR-11 Family
 - o UMRR-11 Type 44
 - o UMRR-11 Type 45
 - o UMRR-11 Type 132

It can be used to implement traffic applications without an additional controller unit being necessary.

The Cabinet Relay Option (CRO) provides both electrical connectors for the cables coming in from the sensor outside the cabinet and multiple stages of electrical surge suppression to protect the cabinet equipment from external surges and noise. This surge protection includes Gas Discharge Tubes (GDTs), Transient Voltage Suppression diodes (TVSs), high-speed resettable electronic fuses (TBUs) and a replaceable fuse.

The surge protection for power, data and relay signals is designed to be compliant to IEC 61000-4-2 (ESD), IEC 61000-4-4 (fast transients) and IEC 61000-4-5 level 4 (lightning surges, severity-level for outdoor equipment).

2.1 FEATURES AND APPLICATIONS

The Cabinet Relay Option (CRO) has the following features:

- Connection to one sensor cable
- Connection to power supply
- Connection for RS485 communication to PC
- Eight configurable solid-state relays per sensor (normally closed (NC) contacts)
- Surge protection on power, communication and relay lines

Important: A CRO can only be connected to one single sensor.

2.2 SYSTEM LAYOUT

The CRO shall be mounted on a DIN rail, as shown exemplary in the picture below.

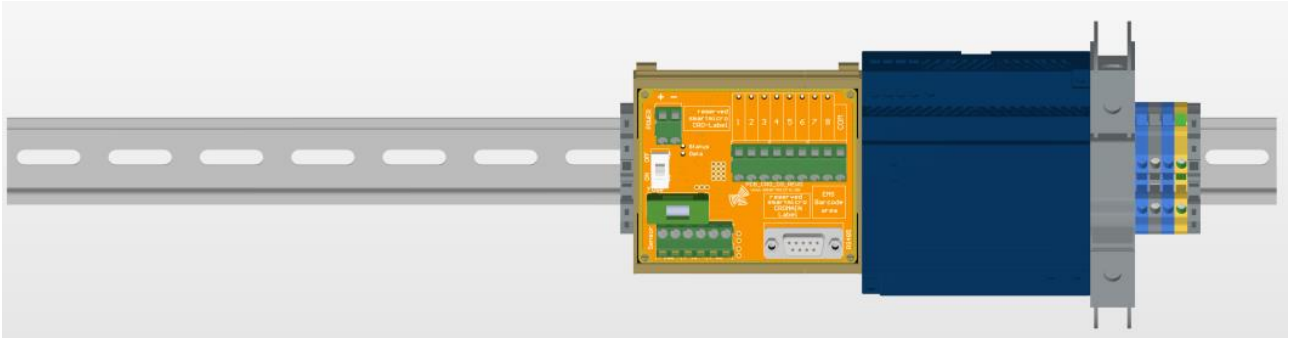

For multiple sensors, multiple CRO devices can be mounted next to each other on the same rail.



The following system layout shows how the CRO can be connected to a smartmicro sensor.

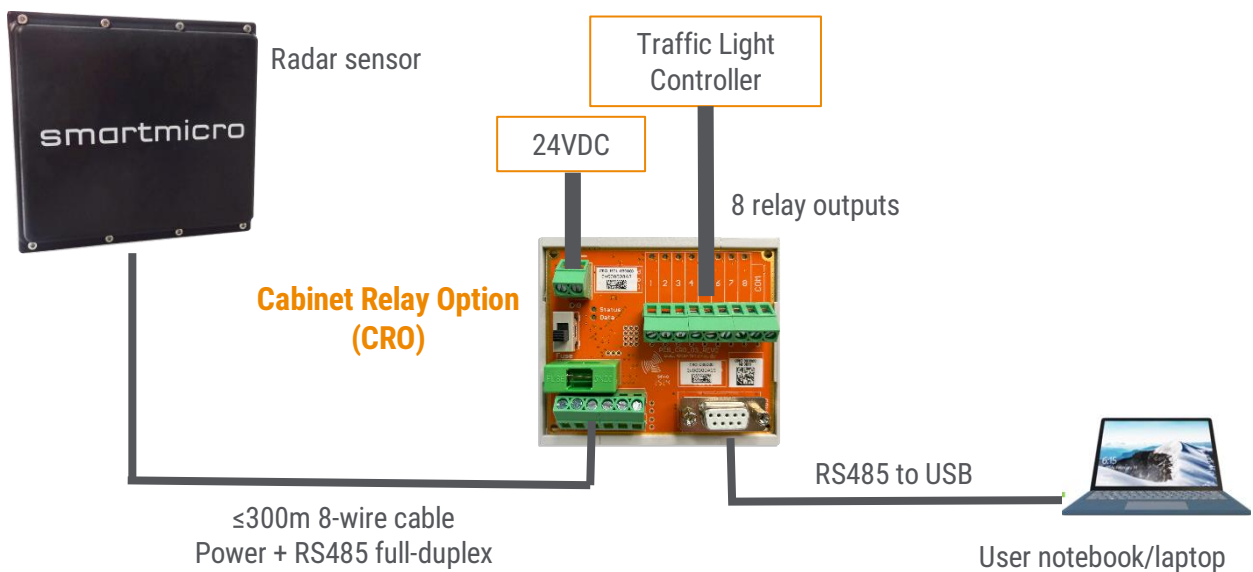

2.3 SOFTWARE CONFIGURATION

The output configuration can be done in the Traffic UI. The Traffic UI installation software simplifies the planning and field installation of smartmicro sensors with an intuitive step-by-step guide. The configuration includes site planning, sensor selection and configuration as well as physically installing the device at an intersection. It can be downloaded from the smartmicro website

In the Traffic UI, under the menu Installation -> Site Plan -> Event Triggers, the first 8 outputs of the output matrix are 1:1 mapped to the relays (see picture below).

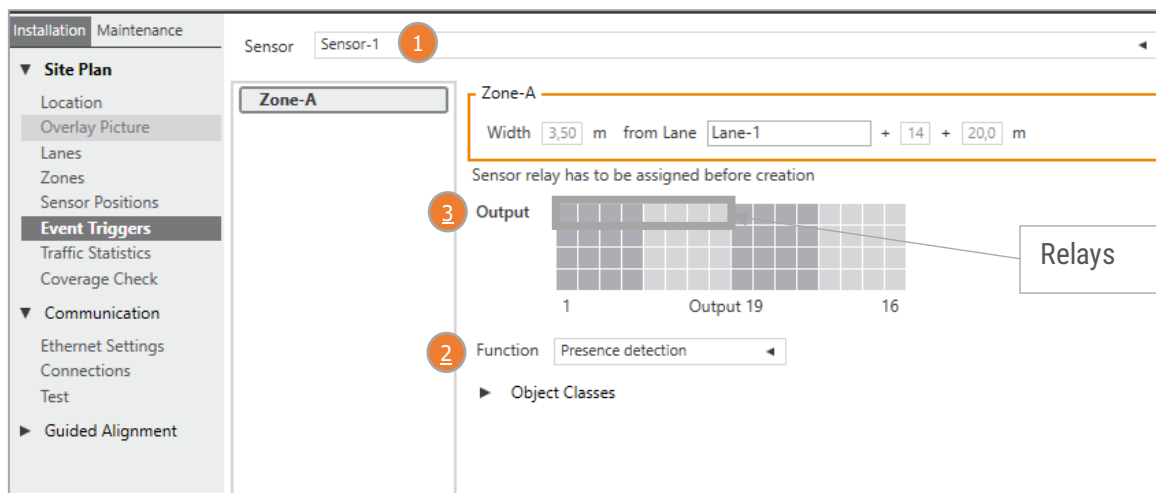

These steps need to be followed to configure every output:

1. Select the sensor from the drop-down list
2. Select the desired function for the trigger
 - Presence
 - Queue
 - Wrong-way
 - Speed trigger
 - Custom
3. Select the desired output in the matrix
4. Repeat the process to configure the next sensor connected to another CRO

2.4 PRODUCT DIMENSIONS

All values are given in mm.

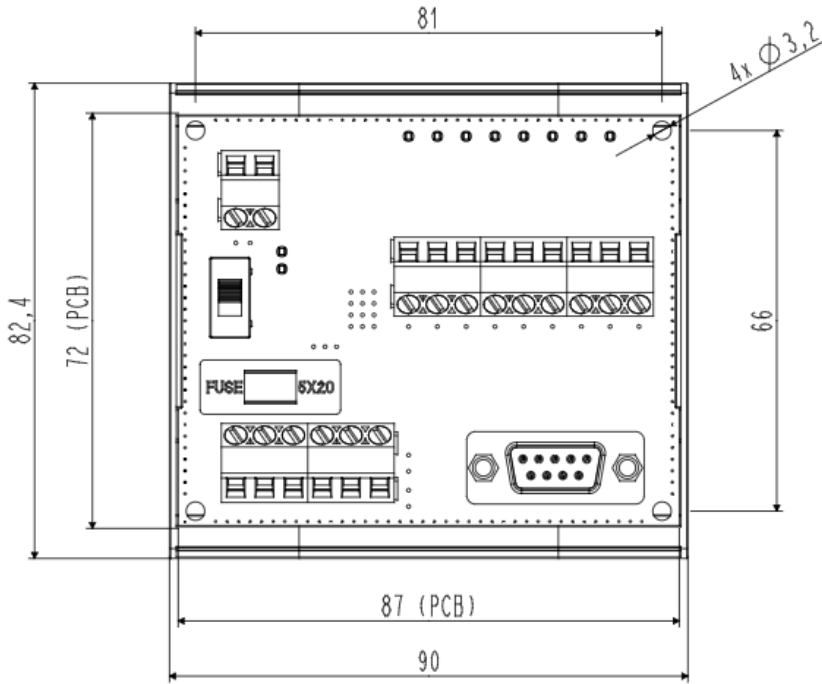

Front Side

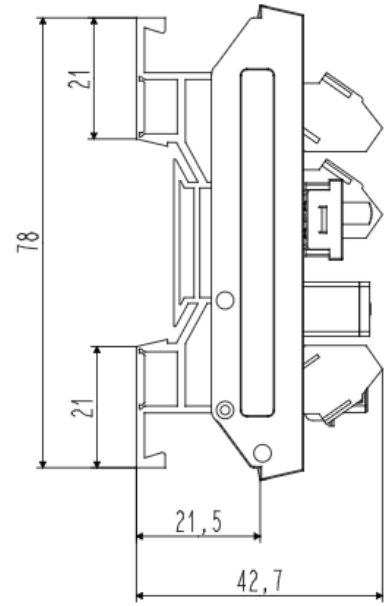

Left Side

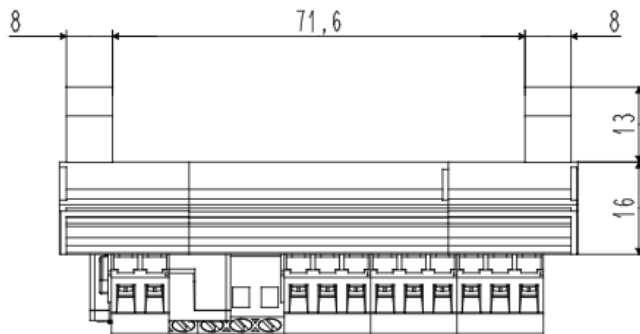

Top Side

2.5 PRODUCT CONNECTORS

Each Cabinet Relay Option (CRO) Module has connectors for input power, a sensor, relays and a user connector.

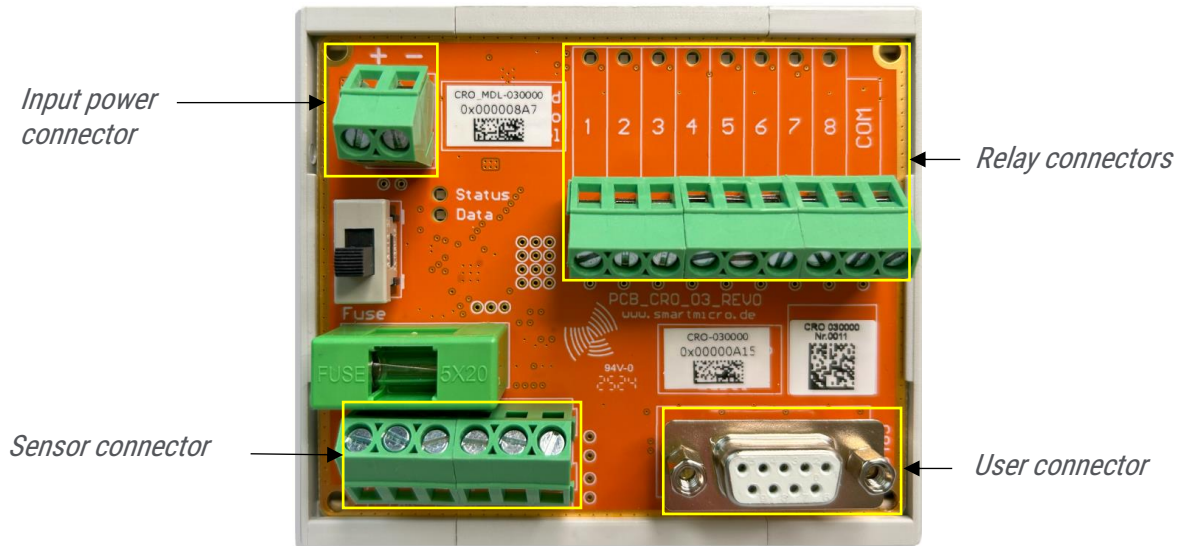

The following table lists all pins and explains their functions.

Connector	Pin No.	Function
Input Power Connector	1	Positive Power Supply (VCC)
	2	Negative Power Supply (GND)
Sensor Connector	1	Sensor VCC
	2	Sensor GND (-)
	3	Sensor RS485 TX H
	4	Sensor RS485 TX L
	5	Sensor RS485 RX H
	6	Sensor RS485 RX L
Relay Connectors	1	Channel 01
	2	Channel 02
	3	Channel 03
	4	Channel 04
	5	Channel 05
	6	Channel 06
	7	Channel 07
	8	Channel 08
	COM	Common connection

User Connector	1	Adapter RS485 TX L
	2	Adapter RS485 TX H
	3	Adapter RS485 RX H
	4	Adapter RS485 RX L
	5	Adapter RS485 GND
	6	NC.
	7	NC.
	8	NC.
	9	NC.

2.6 WIRING DIAGRAMM

Relays are bi-directional, but it is recommended to connect the ‚COM‘ pin to ground. When a zone gets triggered, the relay contact will be closed. Based on the maximum relay current of 170mA, the load impedance shall be greater than 140ohm at 24V. The recommended load impedance value is 1kohm.

In the following, three different schematics will be presented based on the hardware to which the CRO will be connected to.

2.6.1 HARDWARE WITH INTERNAL INPUT RESISTANCE

Usually, traffic controllers have a higher input impedance for their digital or analog input. in this case the CRO relay output can be connected directly to the controller input channel. The traffic controller will configure the internal pull-up or pull-down resistance to have 0V or 24V on active trigger.

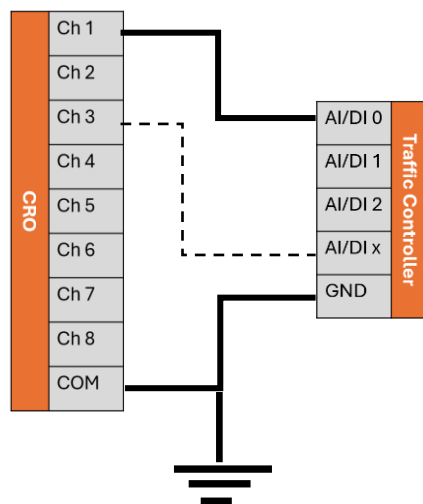

2.6.2 HARDWARE WITHOUT INTERNAL RESISTANCE

For all hardware without internal input resistance for current limitation, 2 use cases are available based on the desired logic, hence, pull-up or pull-down resistance.

2.6.2.1 PULL-UP RESISTANCE

This works as follows:

- Zone is triggered -> relay is closed -> 0V (logic 0) is measured on the hardware input
- Zone is not triggered -> relay is open -> 24V (logic 1) is measured on the hardware input

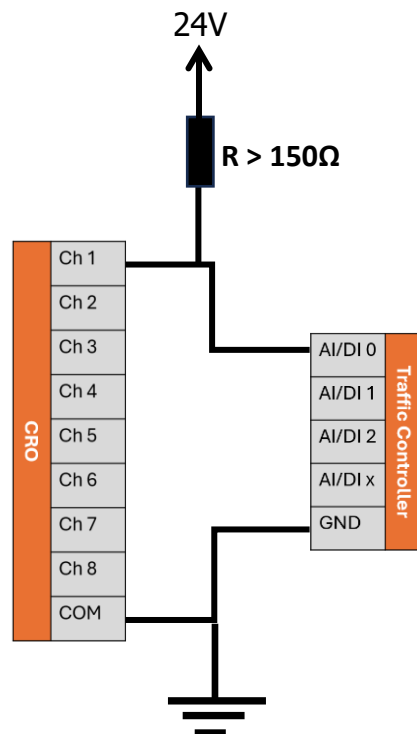

2.6.2.2 PULL-DOWN RESISTANCE

This works as follows:

- Zone is triggered -> relay is closed -> 24V (logic 1) is measured on the hardware input
- Zone is not triggered -> relay is open -> 0V (logic 0) is measured on the hardware input

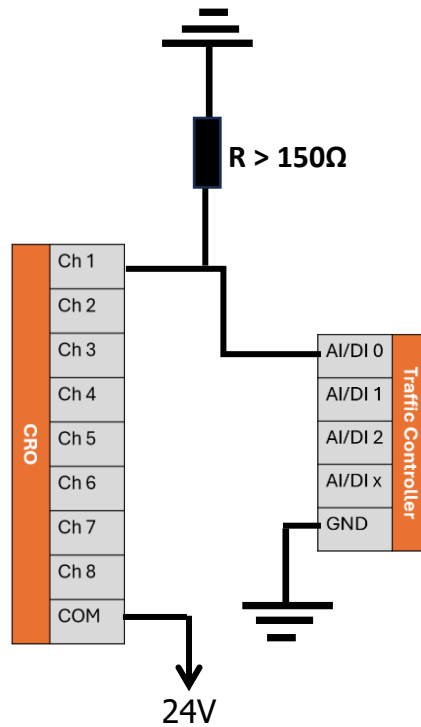

3 CHARACTERISTICS

Parameter	Typical Values (min... max.)	
Temperature	(-40...+85°C) (-40...+185°F)	
Supply Voltage	24V	
Relay Voltage	(0...32V)	
Relay Current	(max. 175mA)	
Outline Dimensions	Height	82.4mm 3.2in
	Width	90mm 3.5in
	Depth	42.9mm 1.7in
Weight	119g 4.2oz	
Supported Cables	AWG 24-12	
Surge Protection of Power Lines, Data Lines & Relay Channels	Compliant to IEC 61000-4-2 (ESD), IEC 61000-4-4 (fast transients) and IEC 61000-4-5 level 4 (lightning surges, severity-level for outdoor equipment).	

4 COMPLIANCES

The Cabinet Relay Option (CRO) complies with the following regulations:

- IEC 61000-4-2 (ESD)
- IEC 61000-4-4 (fast transients)
- IEC 61000-4-5 level 4 (lightning surges, severity-level for outdoor equipment)

5 LEGAL DISCLAIMER NOTICE

All products, product specifications and data in this document may be subject to change without notice to improve reliability, function or otherwise.

Not all products and/or product features may be available in all countries and regions. For legal reasons features may be deleted from products or smartmicro may refuse to offer products. Statements, technical information and recommendations contained herein are believed to be accurate as of the stated date. smartmicro disclaims any and all liability for any errors, inaccuracies or incompleteness contained in this document or in any other disclosure relating to the product.

To the extent permitted by applicable law, smartmicro disclaims (i) any and all liability arising out of the application or use of the product or the data contained herein, (ii) any and all liability of damages exceeding direct damages, including - without limitation - indirect, consequential or incidental damages, and (iii) any and all implied warranties, including warranties of the suitability of the product for particular purposes.

Statements regarding the suitability of products for certain types of applications are based on smartmicro's knowledge of typical requirements that are often placed on smartmicro products in generic/general applications. Statements about the suitability of products for a particular/specific application, however, are not binding. It is the customer's/user's responsibility to validate that the product with the specifications described is suitable for use in the particular/specific application. Parameters and the performance of products may deviate from statements made herein due to particular/specific applications and/or surroundings. Therefore, it is important that the customer/user has thoroughly tested the products and has understood the performance and limitations of the products before installing them for final applications or before their commercialization. Although products are well optimized to be used for the intended applications stated, it must also be understood by the customer/user that the detection probability may not be 100% and that the false alarm rate may not be zero.

The information provided, relates only to the specifically designated product and may not be applicable when the product is used in combination with other materials or in any process not defined herein. All operating parameters, including typical parameters, must be validated for each application by the customer's/user's technical experts. Customers using or selling smartmicro products for use in an application which is not expressly indicated do so at their own risk.

This document does not expand or otherwise modify smartmicro's terms and conditions of purchase, including but not being limited to the warranty. Except as expressly indicated in writing by smartmicro, the products are not designed for use in medical, life-saving or life-sustaining applications or for any other application in which the failure of the product could result in personal injury or death.

No license, expressed or implied, by estoppel or otherwise, to any intellectual property rights is granted by this document or by any conduct of smartmicro. Product names and markings noted herein may be trademarks of their respective owners.

Please note that the application of the product may be subject to standards or other regulations that may vary from country to country. smartmicro does not guarantee that the use of products in the applications described herein will comply with such regulations in any country. It is the customer's/user's responsibility to ensure that the use and incorporation of products comply with regulatory requirements of their markets.

If any provision of this disclaimer is, or is found to be, void or unenforceable under applicable law, it will not affect the validity or enforceability of the other provisions of this disclaimer.