

DATASHEET

TRAFFIC MANAGEMENT EDGE DEVICE

COM HUB® RELAY 24



s.m.s, smart microwave sensors GmbH
In den Waashainen 1
38108 Braunschweig
Germany

Phone: +49 531 39023-0
Fax: +49 531 39023-599
info@smartmicro.de
www.smartmicro.com

CONTENT

1	User Safety Warning.....	3
2	Product Specifications	4
2.1	COM HUB Relay 24 Characteristics	6
2.2	Power Supply	7
2.3	COM HUB Relay 24 Connectors.....	8
2.4	Relays Wiring Diagram.....	9
2.4.1	Hardware with Internal Input Resistance	9
2.4.2	Hardware without Internal Resistance	10
2.4.2.1	Pull-Up Resistance	10
2.4.2.2	Pull Down Resistance.....	11
2.5	COM HUB Relay 24 Dimensions.....	12
3	Accessories.....	13
3.1	PLC J-Box.....	13
3.2	PLC to LAN Converter	13
3.3	SDLC Module	13
3.4	Relay 32 XP Module	13
4	Materials	14
5	Sensor Compatibility	14
6	Wiring Recommendation.....	14
7	Applications.....	15
8	Compliances.....	16
9	Legal Disclaimer Notice	18

1 USER SAFETY WARNING

Please read the entire document carefully before using the device.

INSTALLATION

Please pay attention to the details below before installing and connecting the device:

- Only use provided or approved equipment for the operation.
- Only skilled and instructed people shall install and connect the device.
- All connectors are pin-coded and fit in only one position.
- Be cautious when using the device on or around active roadways and pay attention to moving traffic.
- Make sure that test procedures are in accordance with local safety policies and procedures as well as company practices.

OPERATION

Please note that the device is not waterproof. Take care of proper rain coverage when working outside. Do not operate the device if the device itself or any cables are damaged.

Do not dispose electrical and electronic equipment in household trash.



TECHNICAL SERVICE

Only use provided or approved equipment for operation. Other than authorized and approved electrical technicians should NOT attempt to connect the device to a power supply or other controllers, as there is a risk of electrical shock by unsafe handling of the power source.

Do not attempt to service or repair this device:

- No user-maintainable parts are contained in the device.
- To avoid electrical shock, do not remove or open the cover.
- Unauthorized opening will void all warranties.
- smartmicro is not liable for any damages or harms caused by unauthorized attempts to open or repair the device.

2 PRODUCT SPECIFICATIONS

The smartmicro COM HUB Relay 24 is a high-performance edge device (in cabinet computer) with an interface panel. It enables the connection and time synchronization of up to 4 TOPGRD or TRUGRD sensors via Power Line Communication (PLC), using PLC terminal blocks.

Additionally, there is 1 Ethernet for Uplink, 1 Ethernet for connecting additional modules and 24 relay outputs. It also offers Wi-Fi and secure VPN connection. Moreover, the RS485 connection on the COM HUB Relay 24 allows serial connectivity (via protocol) to traffic controllers.

Besides the front panel board that serves as interface board, the COM HUB Relay 24 includes protection circuitry and a processing board. The interface board can be used to provide power to the sensors, including surge and overvoltage protection for all connected sensors. It also includes status and activity LEDs.

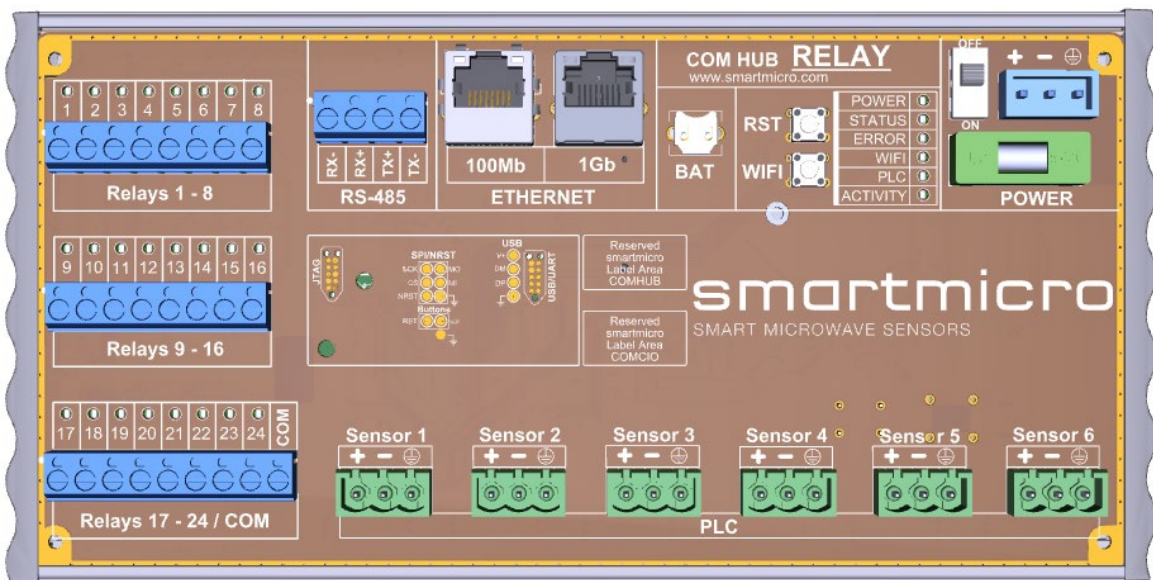

FEATURES

COM HUB Relay 24 has the following features:

- Built-in surge and power protection
- Pluggable terminal block, on/off switch, and fuse for the main DC power supply
- Reset button for software reset
 - o Factory reset: During boot-up, press reset button for 20 seconds until the status LED is solid
 - o IP setting reset: Press reset button for 3 seconds, release the reset button
- PLC interface with 6 pluggable terminal blocks for sensors (important: the maximum number of sensors that can be connected is 4)
- One Gbit speed Ethernet interface and RJ45 LAN connector for Uplink
- One Ethernet Interface for connecting additional modules like SDLC Module or Relay 32 XP Module
- One full-duplex RS485 interface and 4 pin screw terminal block
- 24 configurable solid-state relays (normally closed (NC) contacts) and 24 relay status LEDs
- Wi-Fi communications with on/off button and automatic turn-off feature
- VPN secure connection
- Real-time clock
- LEDs for power, system status, error, Wi-Fi, PLC, activity
- On-board Traffic Web UI user interface for system configuration, monitoring and diagnostics
- Battery for RTC (Real Time Clock)

IMPORTANT NOTES:

- It is required to use a PLC J-Box to connect a TOPGRD sensor or a TRUGRD sensor with COM HUB Relay 24.
- TOPGRD sensors and TRUGRD sensors cannot be mixed.

2.1 COM HUB RELAY 24 CHARACTERISTICS

Parameter		Details
Power Supply	Supply Voltage	48V DC ¹
	Min Input Voltage ²	15V DC
	Max Input Voltage	53V DC
	Max Input Current	max. 10A
Sensor Interfaces	PLC	6 ports (for 4 sensors), transparent bus
Module Interfaces	Ethernet Interface	ETH1: 10/100/1000Mbit (uplink) ETH2: 100Mbit (SDLC, output expansion)
	Wi-Fi Module	Switchable, IEEE 802.11 b/g/n compliant
	RS485 Interface	RS485 Full Duplex
	Status LEDs	Power, Status, Error, Wi-Fi, Activity, PLC
	Dimensions	Outline Dimensions (H/W/D)
	Weight	676 g 23.84 oz
Environment	Operating Temperature	-34...+74°C -29...+165°F
Housing	Case Material	Aluminum/Plastic
Surge Protection	Of Power Lines and Relay	Compliant to IEC 61000-4-2 (ESD) and IEC 61000-4-4 (fast transients)
	Of Data Lines	Compliant to IEC 61000-4-2 (ESD) and IEC 61000-4-4 (fast transients)
Display	Ethernet Activity LEDs	Link and Activity
	LEDs	<div style="background-color: #f0f0f0; padding: 5px;"> <p>Power LED:</p> <ul style="list-style-type: none"> ✓ Active green: power ON ✓ Inactive: power OFF <p>Status LED:</p> <ul style="list-style-type: none"> ✓ Solid green: ongoing update/factory reset ✓ Flashing green: operational (services running) <div style="background-color: #f0f0f0; padding: 5px; margin-top: 5px;"> <p>Error LED:</p> <ul style="list-style-type: none"> ✓ Active red: error (service/application is crashing) </div> </div>

¹ At 48V DC the maximum tested cable length is 300m. The lower the power supply voltage the shorter the allowed cable distance will be.

² Transient voltages above 53V will be suppressed.

	<ul style="list-style-type: none"> ✓ Inactive: no error
	Wi-Fi LED
	<ul style="list-style-type: none"> ✓ Active yellow: Wi-Fi ON ✓ Inactive: Wi-Fi OFF
	HD-PLC LED
	<ul style="list-style-type: none"> ✓ Active yellow: PLC bus is OK (master and slave detected) ✓ Inactive: PLC bus is not OK (master is missing, or no slave is detected)
	Activity LED
	<ul style="list-style-type: none"> ✓ Specific LED coding based on the microprocessor function
	LED display (24 times):
	<ul style="list-style-type: none"> ✓ Active green: relay is closed ✓ Inactive: relay is open
Relay	Terminal block with screw terminals. <ul style="list-style-type: none"> ✓ 12-22 AWG ✓ Relay voltage: 0...48V ✓ Relay switching current: max 150mA

Note: The rechargeable battery for the real-time clock has a limited temperature range of: -20...60°C | -4...+140°F.

2.2 POWER SUPPLY

COM HUB relay 24 can be powered by 24VDC or 48VDC. 24VDC is OK for cable lengths below 100m. To reach a longer cable length, up to 300m, the COM HUB Relay 24 shall be powered with a 48VDC power supply. Make sure that the 3rd party power supply has enough power capacity to supply the COM HUB Relay 24 and the desired number of used sensors.

Sensor Type	Power Consumption (may change with temp.)
TRUGRD	~9.5W
TRUGRD Stream	~11W
TOPGRD	~7W
COM HUB Relay 24	~4.5W

2.3 COM HUB RELAY 24 CONNECTORS

The COM HUB Relay 24 has connectors for input power, 6 connectors for maximum 4 sensors (via PLC), 24 connectors for relays, a connector for RS485, and 2 Ethernet connectors (one for Uplink and one for connecting additional modules).

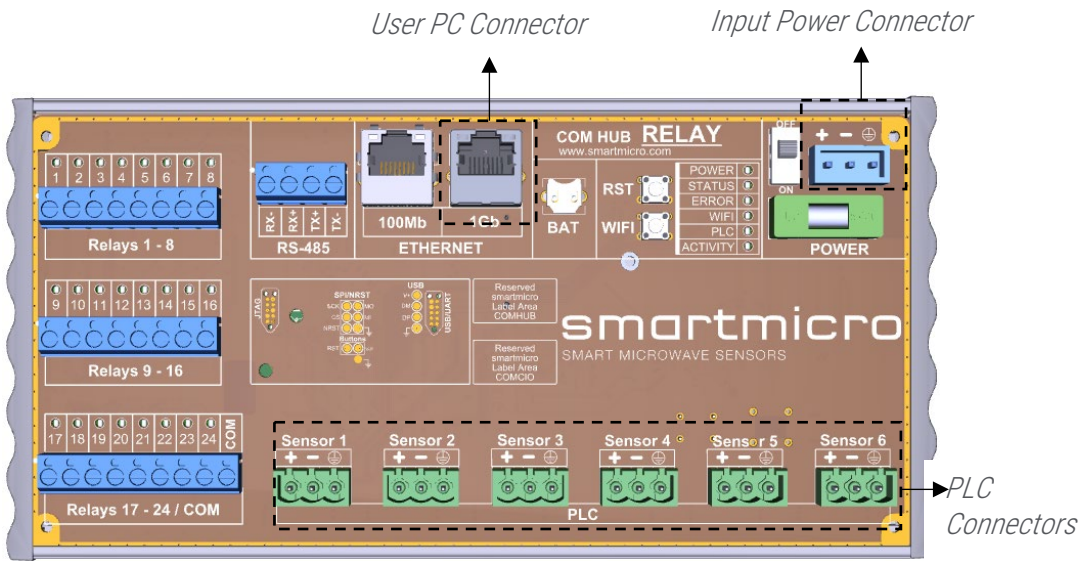

COM HUB Relay 24 interface giving pin descriptions:

Connector	Pin No.	Function
Input Power Connector 1x Pluggable Terminal Block 5mm Supported Cables AWG 24-12	1	Cabinet Earth
	2	Negative Power Supply PWR-
	3	Positive Power Supply PWR+
Sensor PLC Connectors 6x Pluggable Terminal Blocks 5mm Supported Cables AWG 24-12	1	Sensor PWR+
	2	Sensor PWR-
	3	Shield Earth
ETH1 RJ45 Connector		Network: External Default IP: 192.168.12.2/24 (user configurable) Usage: User PC
ETH2 RJ45 connector		Network: Internal

		IP: 192.168.11.2/24 and 192.168.17.2/24 (not user changeable)
		Usage: additional modules like SDLC
RS485 Connector	1	Sensor RS485 RX -
	2	Sensor RS485 RX +
	3	Sensor RS485 TX +
	4	Sensor RS485 TX -
Relay Connector	1 ... 24	Channel 1 ...24
	COM	shared connection for all relays

2.4 RELAYS WIRING DIAGRAM

Relays are bi-directional but it is recommended to connect the ,COM' pin to ground.

When a zone gets triggered the relay contact will be closed. Based on the maximum relay current of 150mA, the load impedance shall be greater than 160ohm at 24VDC. The recommended load impedance value is 1kohm. AC voltage is not allowed. Relays are normally closed (NC) type.

In the following, 3 different schematics will be presented based on the hardware to which the COM HUB Relay 24 will be connected to.

2.4.1 HARDWARE WITH INTERNAL INPUT RESISTANCE

Usually, traffic controllers have a higher input impedance for their digital or analog input. in this case the relay output can be connected directly to the controller input channel. The traffic controller will configure the internal pull-up or pull-down resistance to have 0V or 24V on active trigger.

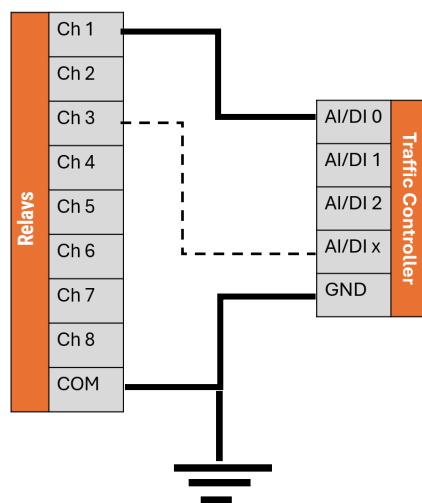

2.4.2 HARDWARE WITHOUT INTERNAL RESISTANCE

For all hardware without internal input resistance for current limitation, 2 use cases are available based on the desired logic, hence, pull-up or pull-down resistance.

2.4.2.1 PULL-UP RESISTANCE

This works as follows:

- Zone is triggered -> relay is closed -> 0V (logic 0) is measured on the hardware input
- Zone is not triggered -> relay is open -> 24V (logic 1) is measured on the hardware input

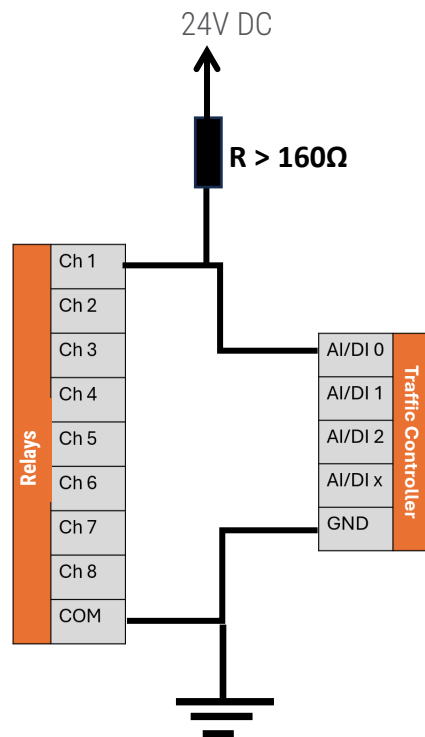

2.4.2.2 PULL DOWN RESISTANCE

This works as follows:

- Zone is triggered -> relay is closed -> 24V (logic 1) is measured on the hardware input
- Zone is not Triggered -> relay is open -> 0V (logic 0) is measured on the hardware input

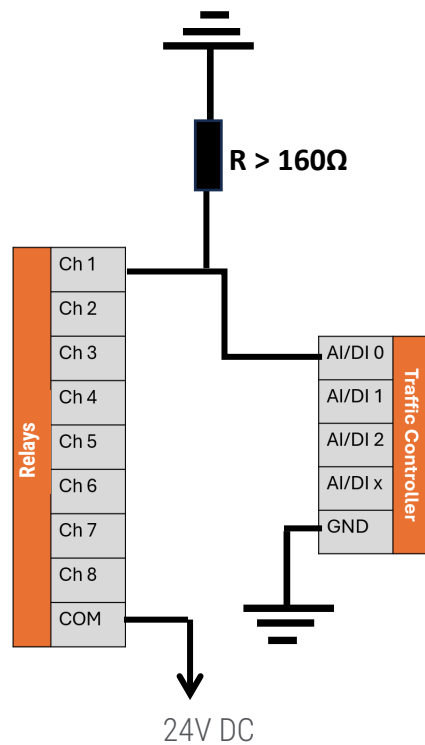

2.5 COM HUB RELAY 24 DIMENSIONS

All values are given in mm and in inch

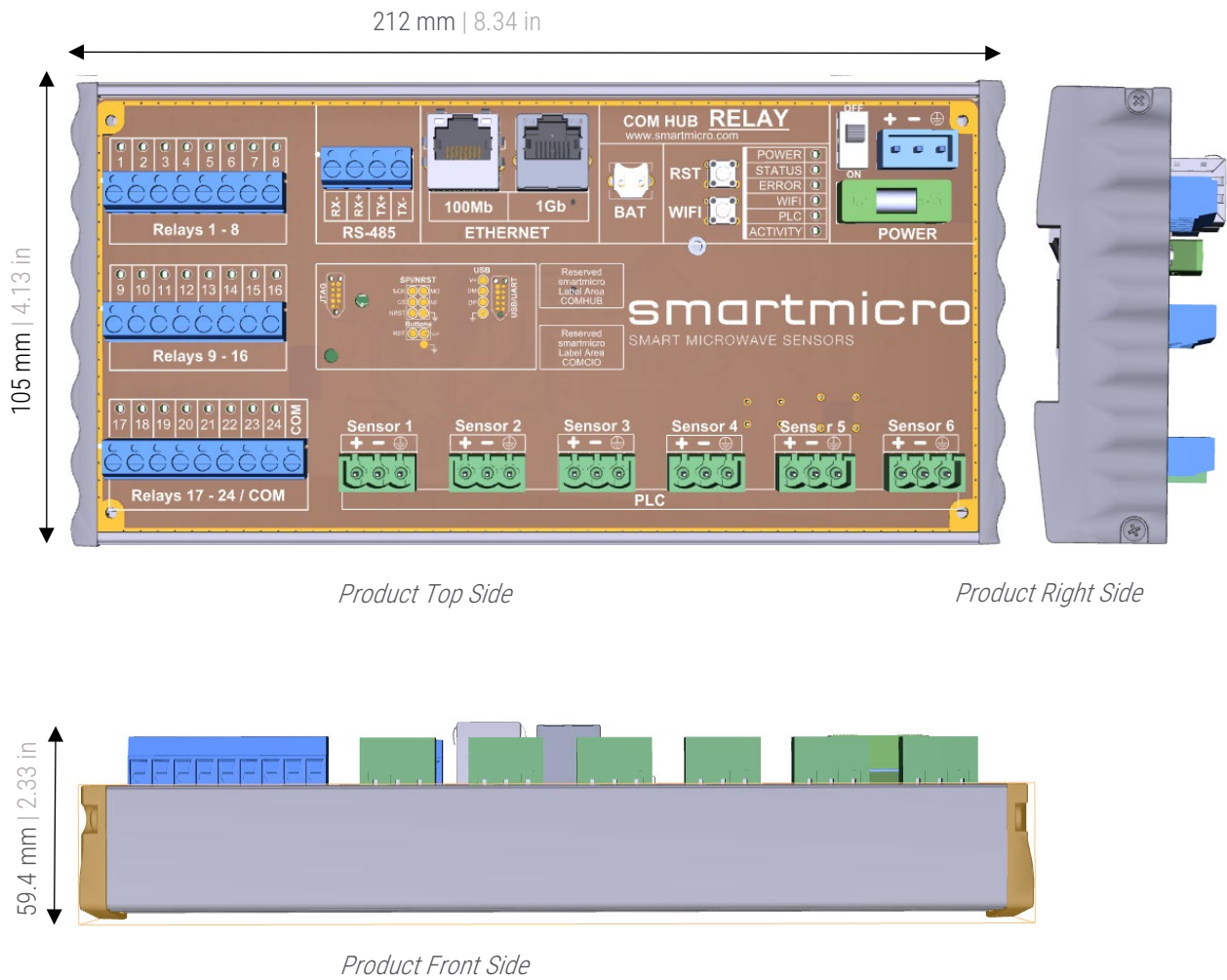

3 ACCESSORIES

There are several accessories available for COM HUB Relay 24.

3.1 PLC J-BOX

When using the COM HUB Relay 24, the PLC J-Box GEN4 is required on the sensor side. It converts in both directions PLC to 4-wire Ethernet.

For more information, please refer to the datasheet of the PLC J-Box.

3.2 PLC TO LAN CONVERTER

Just like the PLC J-Box on sensor side, this terminal converts the PLC data to Ethernet, on the cabinet side. This can be used, for example, if access to the internal network is needed for troubleshooting purposes

For more information, please refer to the datasheet of the PLC to LAN Converter.

3.3 SDLC MODULE

The SDLC Module is compatible with COM HUB Relay 24. It has to be connected to ETH2 of the COM HUB Relay 24 Module. The SDLC Module transmits 64 outputs to the traffic controller via the standard SDLC protocol.

For more details please read the datasheet for the SDLC Module

3.4 RELAY 32 XP MODULE

This module add 32 additional relays, in case the 24 onboard relays are not sufficient.

4 MATERIALS

All parts are made of corrosion-resistant materials, such as plastic, stainless steel, anodized aluminum, brass, or gold-plated metal. COM HUB Relay 24 must be used only inside cabinets. It is not water protected.

5 SENSOR COMPATIBILITY

COM HUB Relay 24 is compatible with the following sensors

- TOPGRD
- TRUGRD
- TRUGRD Stream

COM HUB Relay 24 is currently not compatible with UMRR-11 sensors.

COM HUB Relay 24 will only allow connections to a maximum of 4 sensors of the same product family. Mixing TOPGRD and TRUGRD sensors is not allowed.

6 WIRING RECOMMENDATION

A recommended cable between PLC J-Box and COM HUB Relay 24 is Advanced Digital Cable PVC/Nylon 18AWG, Part Number 6803SD. In case you want to use another cable, please contact smartmicro for approval.

7 APPLICATIONS

Traffic light controllers are typically used to control actuated intersections. They detect the current traffic flow through a set of loop detectors and adjust the signal phases of the traffic lights accordingly. While loop detectors are dependable and robust, they are also cost- and service-intensive.

smartmicro traffic detectors offer cost-effective and seamless loop replacement through above-ground, non-invasive radar technology. To connect the radar sensors to cabinets for loop replacement, COM HUB Relay 24 is used, as it offers onboard relay outputs. The relay output will be connected to the traffic controller.

COM HUB Relay 24 is compatible with TOPGRD and TRUGRD Family sensors. The maximum tested cable length for the PLC communication between a sensor and COM HUB Relay 24 is 300m (984ft).

As explained above, a PLC J-Box is required for each sensor on the sensor end of the cable. Up to 4 sensors can be connected. When using TRUGRD Stream, the mpg video stream is transferred via the same cable and is available for the end user at the ETH1 output of COM HUB Relay 24.

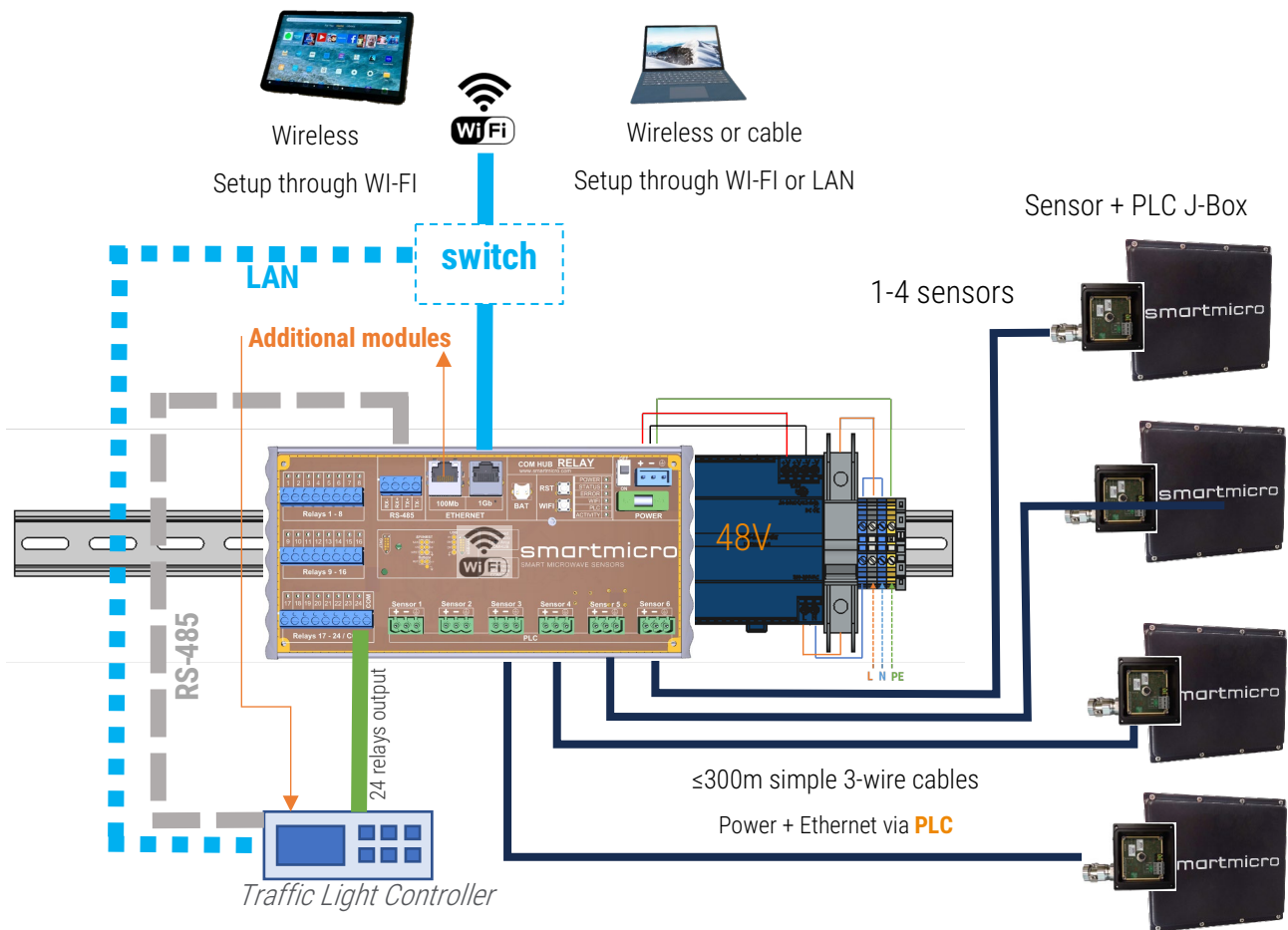

Connecting smartmicro sensors to a controller through COM HUB Relay 24

8 COMPLIANCES³

The COM HUB Relay 24 complies with the following EU directives:

- RED 2014/53/EU
- EMC 2014/30/EU
- Safety 2014/35/EU
- RoHS 2011/65/EU
- EC 1907/2006 REACH

Applied standards:

- Spectrum Usage:
 - o EN 300 328 V2.2.2
- EMC:
 - o EN 301 489-1 V2.2.3
 - o EN 301 489-17 V3.2.4
 - o EN IEC 61000-6-2:2005
 - o EN IEC 61000-6-3:2007+A1:2011 + AC:2012
- Health and Safety:
 - o EN 62311: 2008
 - o EN 62368-1: 2014 + AC: 2015

According to the surge protection, the COM HUB Relay 24 complies also with the following regulations:

- IEC 61000-4-2 (ESD)
- IEC 61000-4-4 (fast transients)
- IEC 61000-4-5 (Surges)

Regarding operating conditions like temperature, vibration etc., the COM HUB Relay 24 will be tested and certified by independent test labs to comply with:

- NEMA TS-2

Regarding spectrum usage, this sensor model will be tested and certified by independent test labs (formally approved by a test lab or notified body):

- EU RED directive
- EU EMC directive
- 47 CFR FCC Part 15 B
- 47 CFR FCC Part 15 C Section 15.247
- ICES 003
- RSS-247

³ Pending

Note: This statement of compliance means that the COM HUB Relay 24 allows operation compliant to the listed standards. However, not all standards are certified through test labs. Formal frequency approval or registration is not accomplished for all countries. In certain countries or regions, a customer-specific local frequency approval is reasonable. smartmicro supports customers throughout this process.

9 LEGAL DISCLAIMER NOTICE

All products, product specifications and data in this document may be subject to change without notice to improve reliability, function or otherwise.

Not all products and/or product features may be available in all countries and regions. For legal reasons features may be deleted from products or smartmicro may refuse to offer products. Statements, technical information and recommendations contained herein are believed to be accurate as of the stated date. smartmicro disclaims any and all liability for any errors, inaccuracies or incompleteness contained in this document or in any other disclosure relating to the product.

To the extent permitted by applicable law, smartmicro disclaims (i) any and all liability arising out of the application or use of the product or the data contained herein, (ii) any and all liability of damages exceeding direct damages, including - without limitation - indirect, consequential or incidental damages, and (iii) any and all implied warranties, including warranties of the suitability of the product for particular purposes.

Statements regarding the suitability of products for certain types of applications are based on smartmicro's knowledge of typical requirements that are often placed on smartmicro products in generic/general applications. Statements about the suitability of products for a particular/specific application, however, are not binding. It is the customer's/user's responsibility to validate that the product with the specifications described is suitable for use in the particular/specific application. Parameters and the performance of products may deviate from statements made herein due to particular/specific applications and/or surroundings. Therefore, it is important that the customer/user has thoroughly tested the products and has understood the performance and limitations of the products before installing them for final applications or before their commercialization. Although products are well optimized to be used for the intended applications stated, it must also be understood by the customer/user that the detection probability may not be 100% and that the false alarm rate may not be zero.

The information provided relates only to the specifically designated product and may not be applicable when the product is used in combination with other materials or in any process not defined herein. All operating parameters, including typical parameters, must be validated for each application by the customer's/user's technical experts. Customers using or selling smartmicro products for use in an application which is not expressly indicated do so at their own risk.

This document does not expand or otherwise modify smartmicro's terms and conditions of purchase, including but not being limited to the warranty. Except as expressly indicated in writing by smartmicro, the products are not designed for use in medical, lifesaving or life-sustaining applications or for any other application in which the failure of the product could result in personal injury or death.

No license, expressed or implied, by estoppel or otherwise, to any intellectual property rights is granted by this document or by any conduct of smartmicro. Product names and markings noted herein may be trademarks of their respective owners.

Please note that the application of the product may be subject to standards or other regulations that may vary from country to country. smartmicro does not guarantee that the use of products in the applications described herein will comply with such regulations in any country. It is the customer's/user's responsibility to ensure that the use and incorporation of products comply with regulatory requirements of their markets.

If any provision of this disclaimer is, or is found to be, void or unenforceable under applicable law, it will not affect the validity or enforceability of the other provisions of this disclaimer.