

# DATASHEET

## 4D/PXHD TRAFFIC MANAGEMENT SENSOR

TOPGRD®

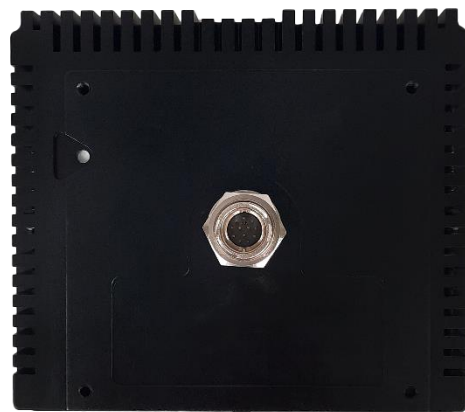

s.m.s, smart microwave sensors GmbH  
In den Waashainen 1  
38108 Braunschweig  
Germany

Phone: +49 531 39023-0  
Fax: +49 531 39023-599  
info@smartmicro.de  
www.smartmicro.com

## CONTENT

1	USER SAFETY WARNING .....	3
2	SENSOR SPECIFICATIONS.....	5
2.1	MEASUREMENT PRINCIPLE.....	5
2.3	SENSOR DIMENSIONS .....	9
2.4	SENSOR CONNECTOR.....	10
2.5	SENSOR AND HARDWARE IDENTIFICATION .....	11
3	GENERAL PERFORMANCE DATA.....	12
3.1	START-UP TIME .....	14
3.2	SELF-DIAGNOSIS.....	14
3.3	SENSOR NETWORK.....	14
3.4	ETHERNET CONNECTION .....	15
4	APPLICATION-SPECIFIC CHARACTERISTICS.....	16
4.1	INTERSECTION APPLICATIONS .....	16
4.2	HIGHWAY APPLICATIONS.....	18
4.3	TRAFFIC ENFORCEMENT.....	20
5	COMPLIANCES.....	22
6	LEGAL DISCLAIMER NOTICE .....	23

## 1 USER SAFETY WARNING

Please read the entire document carefully before using the sensor.

### INSTALLATION

Please pay attention to the details below before installing and connecting the sensor:

- Only use provided or approved equipment for the installation. Use stainless screws with the given metric thread. If other brackets than those provided are used, screw lengths must be adapted.
- Only skilled and instructed persons shall install and connect the sensor. Proper experience in working with mains voltage, electrical and electronic devices is required.
- Do not connect the sensor directly to the mains voltage; instead use the voltage specified for the product.
- Do not wire any connections when power is applied to the device.
- Ground devices carefully to prevent electrical shock.
- All connectors are pin-coded and fit in only one position. Also note the arrow indicating the top side of the sensor.
- Only use fully functional equipment (ladders, aerial work platform, etc.) when working above ground. Staff shall be capable of working at heights.
- Be cautious when installing the sensor on or around active roadways and pay attention to moving traffic.
- Mount the sensor carefully to prevent it from shifting or dropping.
- The sensor must be mounted to a stiff and solid support. Vibration, oscillation or other movement will reduce the sensor performance.
- Make sure that installation methods are in accordance with local safety policies and procedures as well as company practices.

### OPERATION

Do not operate the sensor if the device itself or any cables are damaged.

Transmission of radio frequency waves starts after the sensor is powered up and stops when it is disconnected from power.

Using accessories like a J-Box or SRO does not influence the sensor performance. It is recommended that only one connection interface (i.e. Ethernet or RS485) is used at a time.

For testing purposes, the sensor may be laid on its face when it is powered up, given that the surface or connectors will not be damaged this way. Please note that this position is not intended for permanent use.



The sensor may become hot during operation. Proper hand protection is recommended for maintenance work.



Do not dispose electrical and electronic equipment in household trash.

## TECHNICAL SERVICE

Only use provided or approved equipment for operation. People other than authorized and approved electrical technicians shall NOT attempt to connect the device to a power supply, an Interface Board or other controllers, as there is a risk of electrical shock by unsafe handling of the power source.

Do not attempt to service or repair this device:

- No user-maintainable parts are contained in the device.
- To avoid electrical shock, do not remove or open the cover.
- Unauthorized opening will void all warranties.
- smartmicro is not liable for any damages or harms caused by unauthorized attempts to open or repair the device.

## RADIATION

Operation is subject to the following two conditions:

- This device may not cause harmful interference.
- This device must accept any interference received, including interference that may cause undesired operation.

This device generates radio frequency energy. There are strict limits on continuous emission power levels to provide reasonable protection against harmful interference when the equipment is operated in a commercial environment.

- Human exposure to transmitted waves from this device is generally considered as safe. Still, it is considered good practice that humans are not subject to higher radiation levels than necessary.

This device may interfere with other devices using the same frequency band.

## 2 SENSOR SPECIFICATIONS

TOPGRD is a 76-77 and 79-80GHz radar sensor for multi-lane, multi-object tracking traffic management applications that features 4D/PxHD technology.

The sensor's antenna aims at long range and wide horizontal angular coverage. With the combination of its 6 TX and 8 RX antennas, forming a 48 virtual TRX antenna array, the sensor can achieve a high angular resolution. The sensor has multiple modes of operation – all with wide field of view:

- An extra-long-range mode for up to 240m range
- An extra-medium-range mode for up to 100m range

### 2.1 MEASUREMENT PRINCIPLE

The sensor measures range, radial speed, horizontal and vertical angle, reflectivity and more parameters of multiple stationary and moving reflectors (targets) simultaneously. It is capable of Pixel-high definition (4D/PxHD). Through MIMO antenna operation and super resolution algorithms, the sensor achieves a particularly high azimuth angular separation capability<sup>1</sup> (PxHD) and elevation measurement, depending on its configuration.

smartmicro radars employ a patented A/B fast chirp-sequence frequency-modulated continuous wave (A/B CS-FMCW) modulation.

FMCW radars can natively separate targets in two dimensions: Range and speed. Transmitting, receiving, and processing a single linear frequency ramp (chirp) enables the radar to detect and separate multiple targets within the radar's field of view.

CS-FMCW radars use multiple chirps as part of one measurement (one radar cycle). The results from multiple chirp range measurements are coherently processed, allowing the radar to measure the Doppler frequency of a target over the measurement time (typically in the order of 10-40ms). High-speed, low-speed and even stationary targets are detected by the smartmicro radar.

smartmicro's patented A/B CS-FMCW technology then allows for direct unambiguous Doppler measurement (covering the complete specified speed interval) in one single measurement cycle.

The sensor is almost unaffected by weather, temperature, and lighting conditions. It withstands high shock and vibration levels, is maintenance free and made for a long lifetime.

<sup>1</sup> Separation in azimuth angle is not available yet.

## 4D/PxHD MEASUREMENT

A 4D Doppler based radial motion detection principle is integrated:

- a) Direct unambiguous Doppler measurement (speed)
- b) Direct range measurement
- c) Direct azimuth angle measurement (horizontal angle)
- d) Direct elevation angle measurement (vertical angle)

Moving reflectors can be detected as well as stationary reflectors.

With its multi-target capability, the sensor can *detect* many reflectors within the field of view at a time (max. 128 or 256<sup>2</sup>). The field of view covers up to ten lanes. Additionally, filter algorithms are implemented for the tracking of all detected traffic objects (traffic participants) over time. Those tracking algorithms are integrated in the sensor. Multiple objects (max. 64 or 128<sup>2</sup>) can be *tracked* simultaneously. Depending on the selected communication interface, the number of *reported* targets and objects may be limited, for example when using RS485 interface. Both, targets and objects, are sorted by range; those with shorter range are reported first.

The result of tracking is an object list with the following parameters:

- X-position
- Y-position
- Absolute velocity
- Heading angle
- Length
- Object ID and more

In addition, status and diagnose data from the sensor are reported. The sensor reports a list of all tracked objects in every measurement cycle of typically  $\leq 55$ ms length.

<sup>2</sup> For this parameter special firmware is needed.

## PIXEL-HIGH DEFINITION RESOLUTION - OBJECT SEPARATION PERFORMANCE

The sensor can separate objects even in areas where many vehicles are closely spaced: for example, in multi-lane scenarios with dense traffic like traffic jams, stop-and-go traffic or at busy intersections. The sensor measures object parameters in 4 dimensions: range, radial speed, azimuth and elevation angle. It also separates in range cells, Doppler cells and azimuth beams (PxHD).

Individual reflectors are separated by detection algorithms if having either:

- A different radial speed value or
- A different range value or
- A different azimuth angular position

Additionally, the elevation angle is measured.

Tracking algorithms and a priori configuration further support the accurate detection and tracking of many traffic participants simultaneously.

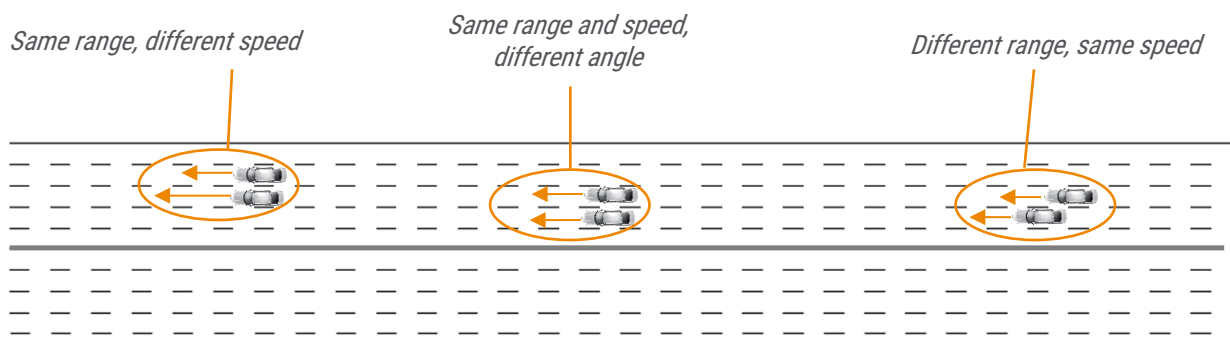

## USER CONFIGURABILITY

The operational mode and frequency band are user-configurable:

The sensor allows to switch between x-medium- and x-long-range mode. The modes differ regarding the waveform and the detection performance. The maximum range of all modes is at boresight.

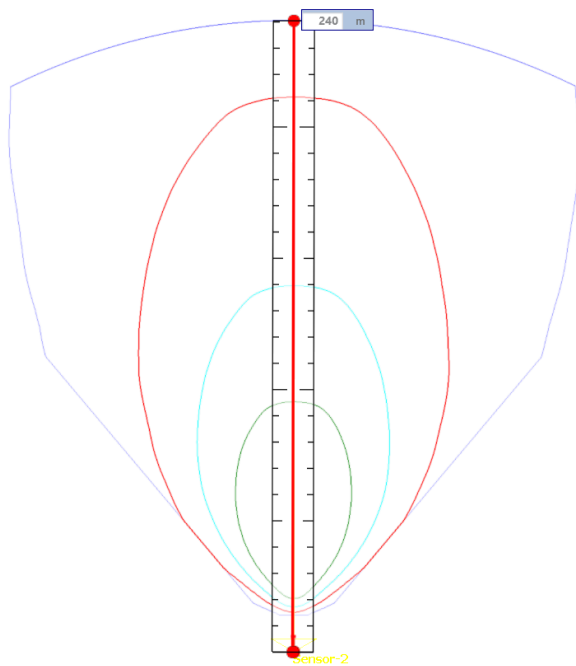

Beam for x-long-range mode (waveform 2)

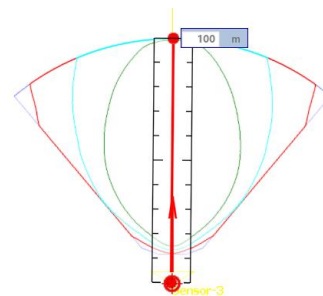

Beam for x-medium-range mode (waveform 3)

## 2.2 SENSOR BEAMS

For x-long- and x-medium-range modes, multiple non-overlapping frequency bands are available to reliably avoid mutual interference. Four frequency bands are available for x-long-range mode and two for x-medium-range mode.



### 2.3 SENSOR DIMENSIONS

All values are given in mm.

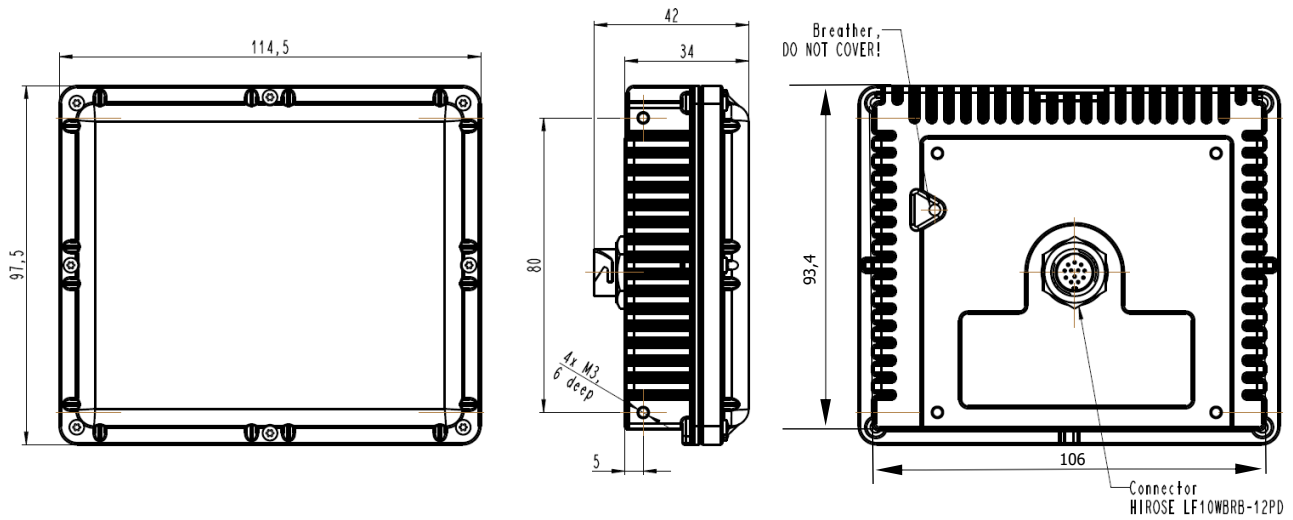

Sensor Front Side

Left Side

Sensor Rear Side

## 2.4 SENSOR CONNECTOR

The sensor connector is a 12-pin male (plug) circular bayonet type connector (water proof IP67). A female counterpart (socket), e.g. LF10WBP-12S, must be used to connect with the sensor.

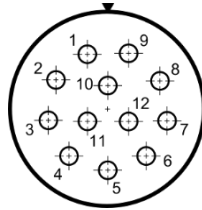

*View on solder cup side of socket showing the pin numbering  
(rear view of female counterpart to be connected to sensor)*

Sensor connector pin out model giving pin descriptions:

Pin No.	Function	Wire Color (MEDI type #KU110C12J002)
1	Sensor Ethernet TX H	Gray / red
2	Sensor Ethernet TX L	Red / blue
3	Sensor RS485 RX L	Pink
4	Sensor RS485 RX H	Gray
5	Sensor RS485 TX L	Brown
6	Sensor RS485 TX H	White
7	Sensor_GND	Blue
8	Sensor_Vcc	Red
9	Sensor Ethernet RX L	Black
10	Sensor Ethernet RX H	Purple
11		
12		

For the RS485 data interface there are 120 Ohms resistors on board of the sensor. Such resistors are required at either end of a RS485 bus (TX pair and RX pair).

Several cable sets for initial operation and test purposes are offered by smartmicro, to deliver a fast set-up of a sensor system. Among those preconfigured ready-to-run cables as well as cable stumps (pig tail cables or various lengths) which carry the connector on one side and open wires on the other.

## 2.5 SENSOR AND HARDWARE IDENTIFICATION

The sensor housing is tagged with a type sticker containing the product description and the serial number. It also indicates which side of the sensor is the top side.

Sticker example:



Additionally, the DSP board and the RF board have their own unique serial numbers.

### 3 GENERAL PERFORMANCE DATA

Parameter		X-Long-Range Mode	X-Medium-Range Mode
Operating Frequency		76...77GHz	76...77GHz
Center Freq. (Bands) <sup>3</sup>		or 79...80GHz 4 center frequencies (bands)	or 79...80GHz 2 center frequencies (bands)
Range	Minimum	1.2m   3.93ft	0.5m   1.64ft
	Max.: Passenger Car <sup>4</sup>	240m   787ft	98m   321.5ft
	Max.: Truck <sup>4</sup>	240m   787ft	98m   321.5ft
	Instrumented <sup>5</sup>	240m   787ft	98m   321.5ft
	Separation	≤ 2.4m   ≤ 7.8ft	< 1m   < 3.2ft
	Accuracy <sup>6</sup>	< 0.6m   < 1.96ft	< 0.25m   < 0.82ft
Speed	Min./Max.		-320...+320km/h   -199...+199mph
	Separation		< 0.26m/s
	Accuracy <sup>7</sup>		≤ +0.07m/s or ± 1% (bigger of)
Angle	Field of View: Azimuth <sup>8</sup>		-50...+50°
	Field of View: Elevation <sup>9</sup>		-10...+10°
	Separation: Azimuth <sup>10</sup>		2°
	Accuracy: Azimuth <sup>11</sup>		≤ 0.25°
	Accuracy: Elevation <sup>12</sup>		≤ 0.5°
	<b>Mechanical Details</b>		
Weight		485g   17.10oz	
Dimensions (H/W/D)		97.5 x 114.7 x 34mm   3.8 x 4.4 x 1.3in (plus connector)	
<b>Further Information</b>			
Initialization Time		< 10s	

<sup>3</sup> Cannot be selected at runtime – sensors must be ordered to meet frequency regulations: 76-77GHz band in most countries, 79-80GHz band in China. Inside the band, however, the center frequency can be selected at runtime.

<sup>4</sup> Typical values; all values given for bore sight; they may vary depending on the clutter environment. Please note that the radar system can neither achieve a detection probability of 100% nor a false alarm rate equal to zero.

<sup>5</sup> The instrumented range indicates the maximum range at which the sensor can effectively process detections.

<sup>6</sup> Typical value for 10dBm<sup>2</sup> reflector at slow/medium speed; may vary to higher or lower values depending on clutter environment, at bore sight. Reduced for high-speed targets.

<sup>7</sup> Measured on point reflector having constant radial speed, at bore sight.

<sup>8</sup> The total field of view is an angle interval in which reflectors can be detected; 3dB field of view is narrower.

<sup>9</sup> The total field of view is an angle interval in which reflectors can be detected; 3dB field of view is narrower.

<sup>10</sup> Measured for two point reflectors at bore sight with >25dB S/N. Falls off toward larger absolute angles. Not available yet, will become available through s/w update.

<sup>11</sup> Typical value; measured at target output level at bore sight, for a point reflector showing >25dB SNR. Error may increase towards larger angles. In addition to this angle error, due to RFIC characteristics, angle may have an offset which changes over temperature (-40...+85°C), typically -0.25deg to +0.25deg over specified operation temperature interval.

<sup>12</sup> Typical value; measured at target output level at bore sight, for a point reflector showing >25dB SNR. Error may increase towards larger angles. In addition to this angle error, due to RFIC characteristics, angle may have an offset which changes over temperature (-40...+85°C), typically -1.25deg to +1.25deg over specified operation temperature interval.

Update Cycle Time <sup>13</sup>	≤ 55ms
Processing Latency	2-4 cycles
Operating Voltage <sup>14</sup>	7...32V
Power Consumption <sup>15</sup>	<7W
Bandwidth	< 1000MHz
Max. Transmit Power (EIRP)	< 45dBm
Operating & Storage Temperature	-40...+85°C   -40...+185°F
Interfaces <sup>16</sup>	RS485 full duplex; Ethernet 10/100;
Connector	Hirose LF10 series
Shock / Vibration	tba g <sub>rms</sub> / tba g <sub>rms</sub>
Relative Humidity	0...95% (non-condensing)
IP <sup>17</sup>	67
Pressure or Transport Altitude	0...10000m   0...32800ft

<sup>13</sup> Typical value; may be longer depending on the number of detected radar targets.

<sup>14</sup> Measured at the connector.

<sup>15</sup> Depending on supply voltage and temperature; Power consumption decreases with lower voltage and lower temperature.

<sup>16</sup> It is recommended to use an external surge protection for power, RS485 and Ethernet.

<sup>17</sup> IP67 only when connector or cap is attached.

### 3.1 START-UP TIME

After powering up or resetting, sensor readings meet the specified performance in <10s.

### 3.2 SELF-DIAGNOSIS

The sensor cyclically reports a status message providing the following information: sensor run time, sensor cycle time, sensor mode and diagnosis information.

The sensor has a self-diagnosis feature to allow limited fail-safe capabilities, detecting for example:

- Sensor blindness
- Rain
- Misalignment in roll or pitch angle
- Detection and automatic suppression of RF interference (signals from other radar sensors in same frequency band)

### 3.3 SENSOR NETWORK

Sensors are typically used standalone. However, at intersections up to six sensors can be connected to a COM HUB using separate configurable frequency channels, or time slots, which avoid mutual interference.

### 3.4 ETHERNET CONNECTION

The sensor supports UDP via Ethernet in a Local Area Network (LAN). Communication over low bandwidth environments (not less than 100Mbps recommended) or routed networks such as the world wide web are not supported.

Features:

- Ethernet standards IPv4, ARP, IGMP, IP multicast and UDP
- smartmicro's proprietary communication protocol "smartmicro transport protocol" with with sensor data transmission, which sends a list of detected targets every radar cycle. Operation parameters can be accessed via Ethernet.

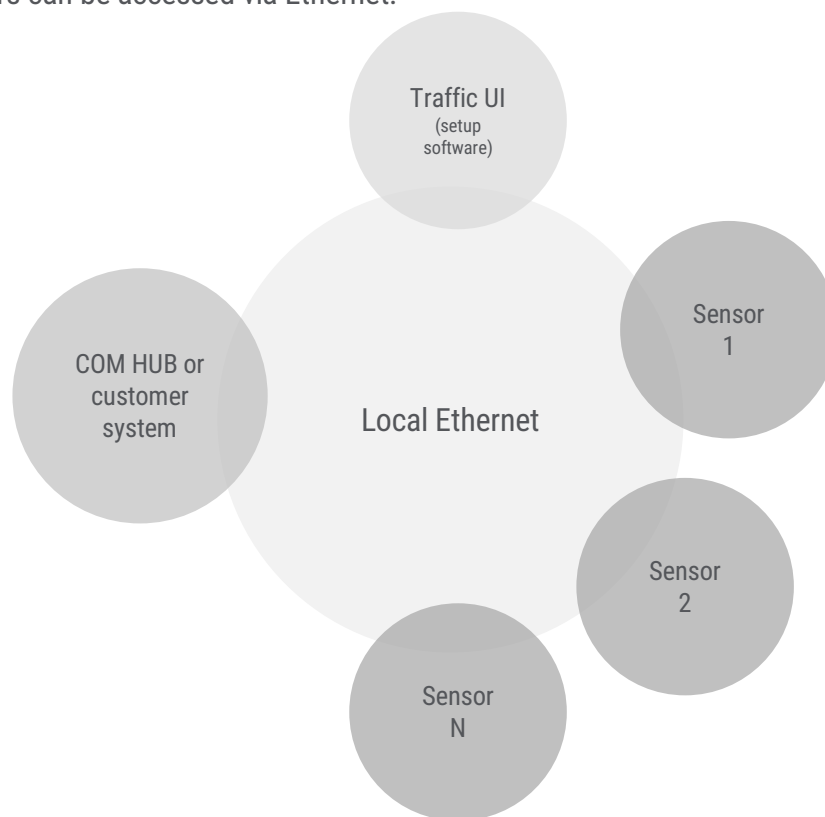

## 4 APPLICATION-SPECIFIC CHARACTERISTICS

The sensor can be used for the following different applications: intersection management, highway management, and enforcement.

### 4.1 INTERSECTION APPLICATIONS

#### Stop + Advance

At intersections, the sensor is typically used for combined stop bar detection (true presence detection) and lane-specific advance detection (exploiting the x long range). Other features of the sensor are:

- Queue length measurement
- Custom trigger conditions (e.g. location, vehicle speed, classification)
- ETA measurement
- Speed measurement

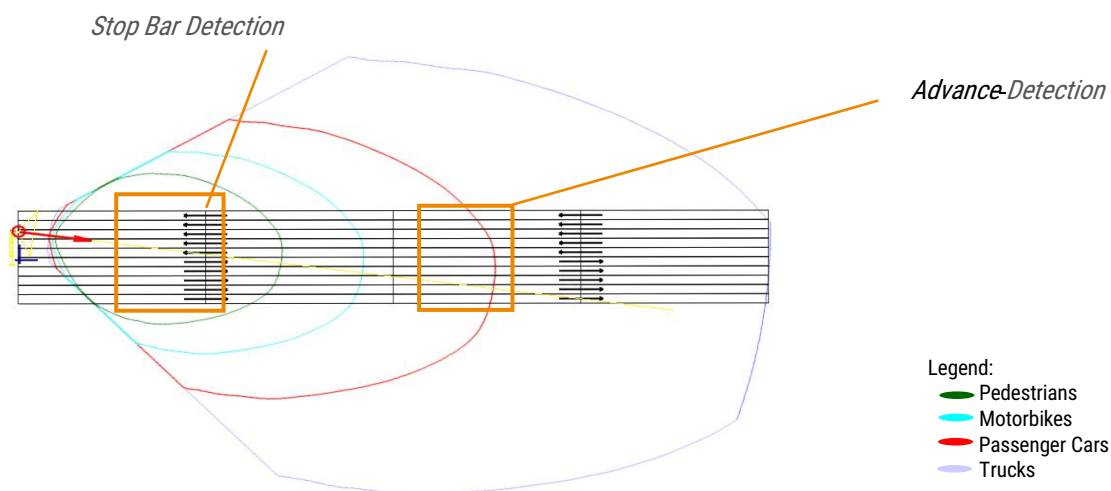



## Standard configuration:

Parameter		Typical Values (min...max.)
Mounting Height <sup>18</sup>		6m (1...10m)   20ft (3...33ft)
Angle <sup>19</sup>	Sensor Azimuth Angle	-8° (-15...+15°)
	Sensor Elevation Angle <sup>20</sup>	-8° (-12...0°)
Stop Bar Setting <sup>21</sup>		25m (15...80m)   82ft (49...262ft)
Further Information		
Cycle Time <sup>22</sup>		55ms

<sup>18</sup> The mounting height may affect the maximum detection range. Occlusion needs to be considered.

<sup>19</sup> The best performance is typically achieved at the center of the given angular range.

<sup>20</sup> These values are application specific. For gantry mounting a steeper elevation angle is possible but limiting the maximum range. A negative elevation angle means that the sensor is pointing towards the road.

<sup>21</sup> Do not use stop bar distances below 15m (at max. sensor elevation mounting angle -12°). Outside the recommended range, vehicle drops are more likely.

<sup>22</sup> Typical value; may be longer depending on the number of detected radar targets.

## 4.2 HIGHWAY APPLICATIONS

On highways and country roads, the sensor can be utilized to count and classify traffic. Usually, statistic details are selected and reported in configurable intervals. Otherwise, already collected statistic data can be retrieved in push mode. Every vehicle can be displayed as per vehicle record (PVR) in real-time.

Other features of the sensor are wrong way detection, support of incident detection and speed measurement. The sensor delivers the following data:

- Classification
- Volume
- Occupancy
- Average speed
- Vehicle presence
- 85 percentile speed
- Headway
- Gap
- Wrong-way detection

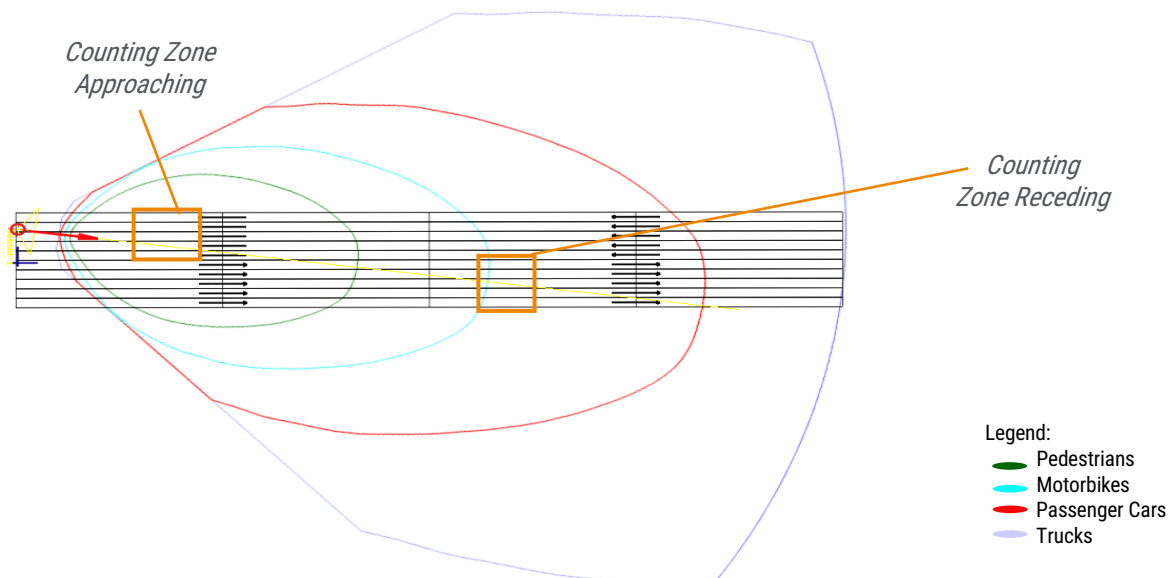

## Standard configuration:

Parameter	Typical Values (min...max.)	
Mounting Height <sup>23</sup>	6m (4...10m)   20ft (13...33ft)	
Angle <sup>24</sup>	Sensor Azimuth Angle	-8° (-15...+15°)
	Sensor Elevation Angle <sup>25</sup>	-4° (-12...0°)
Counting Line Setting <sup>26</sup>	Approaching	30m (20m...80m)   98ft (66...262ft)
	Receding	120m (100m...170m)   393ft (328...557ft)
Setback	1m (0...10m)   3ft (0...33ft)	
Further Information		
Counting Accuracy <sup>27</sup>	> 95%	
Classification Accuracy <sup>28</sup>	> 80%	
Cycle Time <sup>29</sup>	55ms	
Classes	7 (Pedestrian, Bicycle, Motorbike, Passenger Car, Transporter, Truck, Long Truck)	

<sup>23</sup> The mounting height may affect the maximum detection range. Occlusion needs to be considered.

<sup>24</sup> The best performance is typically achieved at the center of the given angular range.

<sup>25</sup> These values are application-specific. For gantry mounting a steeper elevation angle is possible but limiting the maximum range. A negative elevation angle means that the sensor is pointing towards the road.

<sup>26</sup> Outside the recommended range, vehicle drops are more likely.

<sup>27</sup> This is a typical value for a sensor that is properly installed at a suitable location. The counting and classification accuracy mainly depend on the mounting height and the traffic density as well as other factors.

<sup>28</sup> This is a typical value for a sensor that is properly installed at a suitable location. The counting and classification accuracy mainly depend on the mounting height and the traffic density as well as other factors. Not available yet.

<sup>29</sup> Typical value; may be longer depending on the number of detected radar targets.

### 4.3 TRAFFIC ENFORCEMENT<sup>30</sup>

For traffic enforcement purposes the sensor can be used for combined lane-specific speed and red-light enforcement. The sensor can track 64 objects simultaneously<sup>31</sup>. The x-medium-range mode is well adapted for this use case.

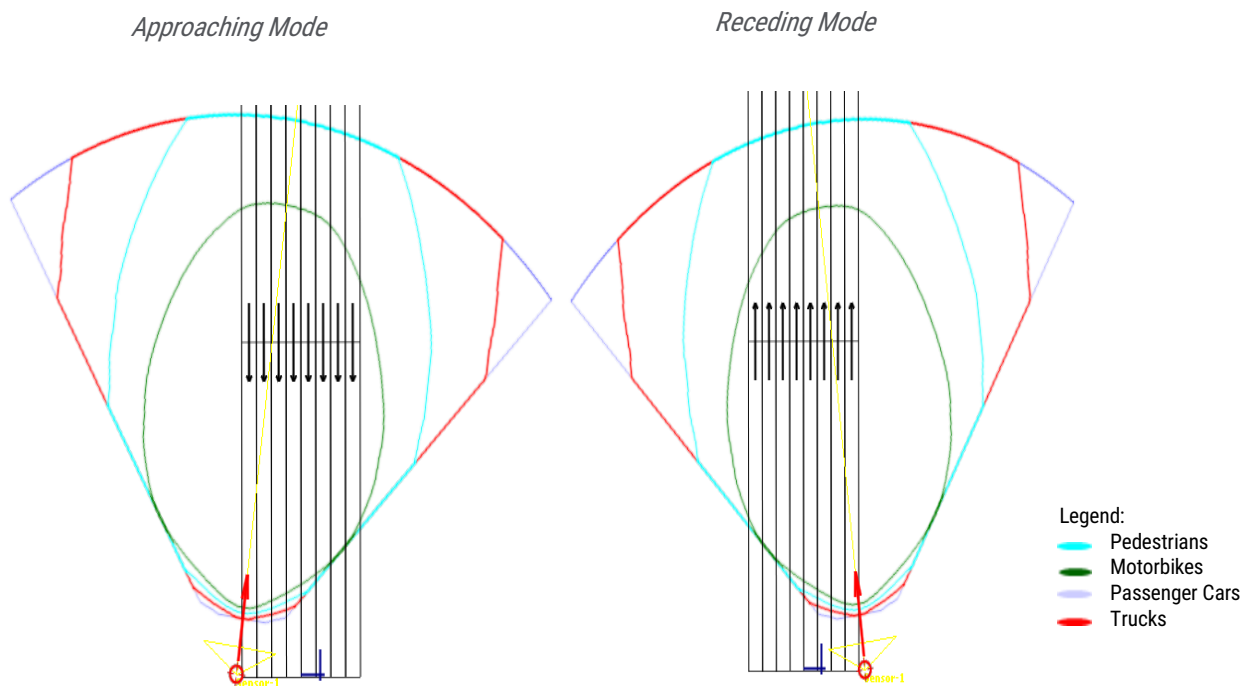

<sup>30</sup> Not available yet.

<sup>31</sup> Up to 128 objects can be tracked using a special firmware.

## Standard configuration:

Parameter	Typical Values (min...max.)	
	Approaching Mode	Receding Mode
Mounting Height <sup>32</sup>	4m/6m (1...10m)   13/20ft (0...33ft)	4m (1...10m) <sup>32</sup>   13ft (3...33ft)
Angle <sup>33</sup>	Sensor Azimuth Angle	-8° (-35...+35°)
	Sensor Elevation Angle <sup>34</sup>	-8° (-12...0°)
Photo Trigger Setting <sup>35</sup>	18m (14...50m)   59ft (45...164ft)	30m (15...50m)   98ft (49...164ft)
Further Information		
Speed Accuracy <sup>36</sup>	< ±0.28m/s ±1% (bigger of)	
Track Initialization Time	6...10 cycles	
Cycle Time <sup>37</sup>	55ms	

<sup>32</sup> The mounting height may affect the maximum detection range. Occlusion needs to be considered.

<sup>33</sup> The best performance is typically achieved at the center of the given angular range.

<sup>34</sup> These values are application specific. For gantry mounting a steeper elevation angle is possible but limiting the maximum range. A negative elevation angle means that the sensor is pointing towards the road.

<sup>35</sup> Outside the recommended range, vehicle drops are more likely.

<sup>36</sup> The speed accuracy is measured on an object having a constant radial speed, at bore sight.

<sup>37</sup> Typical value; may be longer depending on the number of detected radar targets.

## 5 COMPLIANCES<sup>38</sup>

The sensor model complies with the following EU directives:

- RED 2014/53/EU
- RoHS 2011/65/EU
- EC 1907/2006 REACH

Applied Standards:

- Spectrum Usage:
  - 
  - EN 301 091-2 V2.1.1
- EMC:
  - EN 301 489-1 V2.2.0
  - EN 301 489-51 V2.1.0
- Health and Safety:
  - EN 62311: 2008
  - EN 62368-1: 2014 + AC: 2015

Regarding spectrum usage, this sensor model was tested and certified by independent test labs (formally approved by a test lab or notified body):

- EU RED directive
- FCC part 95M
- ISED RSS-251

This sensor model is also generally compliant with the following regional regulations (but may not be formally tested/approved):

- EAC
- ISED/IC
- 
- SRRC
- KCC
- MIIT
- NCC

**Note:** This statement of compliance means that the sensor allows operation compliant to the listed standards. However, not all standards are certified through test labs. Formal frequency approval or registration is not accomplished for all countries. In certain countries or regions, a customer-specific local frequency approval is reasonable. smartmicro supports customers throughout this process.

**Note:** This sensor must not be used for non-automotive (stationary) operation in the USA.

<sup>38</sup> Not yet available.

## 6 LEGAL DISCLAIMER NOTICE

All products, product specifications and data in this document may be subject to change without notice to improve reliability, function or otherwise.

Not all products and/or product features may be available in all countries and regions. For legal reasons features may be deleted from products or smartmicro may refuse to offer products. Statements, technical information and recommendations contained herein are believed to be accurate as of the stated date. smartmicro disclaims any and all liability for any errors, inaccuracies or incompleteness contained in this document or in any other disclosure relating to the product.

To the extent permitted by applicable law, smartmicro disclaims (i) any and all liability arising out of the application or use of the product or the data contained herein, (ii) any and all liability of damages exceeding direct damages, including - without limitation - indirect, consequential or incidental damages, and (iii) any and all implied warranties, including warranties of the suitability of the product for particular purposes.

Statements regarding the suitability of products for certain types of applications are based on smartmicro's knowledge of typical requirements that are often placed on smartmicro products in generic/general applications. Statements about the suitability of products for a particular/specific application, however, are not binding. It is the customer's/user's responsibility to validate that the product with the specifications described is suitable for use in the particular/specific application. Parameters and the performance of products may deviate from statements made herein due to particular/specific applications and/or surroundings. Therefore, it is important that the customer/user has thoroughly tested the products and has understood the performance and limitations of the products before installing them for final applications or before their commercialization. Although products are well optimized to be used for the intended applications stated, it must also be understood by the customer/user that the detection probability may not be 100% and that the false alarm rate may not be zero.

The information provided, relates only to the specifically designated product and may not be applicable when the product is used in combination with other materials or in any process not defined herein. All operating parameters, including typical parameters, must be validated for each application by the customer's/user's technical experts. Customers using or selling smartmicro products for use in an application which is not expressly indicated do so at their own risk.

This document does not expand or otherwise modify smartmicro's terms and conditions of purchase, including but not being limited to the warranty. Except as expressly indicated in writing by smartmicro, the products are not designed for use in medical, life-saving or life-sustaining applications or for any other application in which the failure of the product could result in personal injury or death.

No license, expressed or implied, by estoppel or otherwise, to any intellectual property rights is granted by this document or by any conduct of smartmicro. Product names and markings noted herein may be trademarks of their respective owners.

Please note that the application of the product may be subject to standards or other regulations that may vary from country to country. smartmicro does not guarantee that the use of products in the applications described herein will comply with such regulations in any country. It is the customer's/user's responsibility to ensure that the use and incorporation of products comply with regulatory requirements of their markets.

If any provision of this disclaimer is, or is found to be, void or unenforceable under applicable law, it will not affect the validity or enforceability of the other provisions of this disclaimer.