

DATA SHEET

DRONE ALTIMETER (UMRR-11 TYPE 132)

ALL INFORMATION IN THIS DATASHEET IS PRELIMINARY AND SUBJECT TO CHANGE

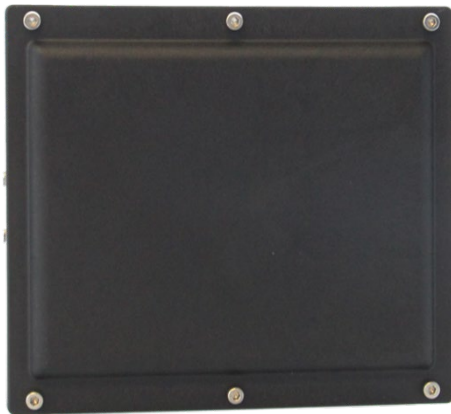

s.m.s, smart microwave sensors GmbH

In den Waashainen 1

38108 Braunschweig

Germany

Phone: +49 531 39023-0

Fax: +49 531 39023-599

info@smartmicro.de

www.smartmicro.com

CONTENT

1	User Safety Warning.....	3
2	Sensor Specifications.....	5
2.1	Mounting Position.....	5
2.2	Sensor Dimensions.....	6
2.3	Sensor Connector.....	7
2.4	Sensor and Hardware Identification.....	8
3	General Performance Data.....	9
3.1	Start-up Time.....	10
3.2	Communication Protocol.....	10
3.3	Altimeter operation.....	10
3.4	Automatic Mode selection.....	12
3.5	Pitch/Roll.....	12
4	Attributions.....	12
5	Compliances.....	13
6	Legal Disclaimer Notice.....	15

1 USER SAFETY WARNING

Please read the entire document carefully before using the sensor.

INSTALLATION

Please pay attention to the details below before installing and connecting the sensor:

- Only use provided or approved equipment for the installation.
- Only skilled and instructed persons shall install and connect the sensor. Proper experience in working with mains voltage, electrical and electronic devices is required.
- Do not connect the sensor directly to the mains voltage; instead use the voltage specified for the product.
- Do not wire any connections when power is applied to the device.
- Ground devices carefully to prevent electrical shock.
- All connectors are pin-coded and fit in only one position. Also note the arrow indicating the top side of the sensor.
- Only use fully functional equipment (ladders, aerial work platform, etc.) when working above ground. Staff shall be capable of working at heights.
- Be cautious when installing the sensor on or around active roadways and pay attention to moving traffic.
- Mount the sensor carefully to prevent it from shifting or dropping.
- The sensor must be mounted to a stiff and solid support. Vibration, oscillation or other movement will reduce the sensor performance.
- Make sure that installation methods are in accordance with local safety policies and procedures as well as company practices.

OPERATION

Do not operate the sensor if the device itself or any cables are damaged.

Transmission of radio frequency waves starts after the sensor is powered up and stops when it is disconnected from power.

For testing purposes, the sensor may be laid on its face when it is powered up, given that the surface or connectors will not be damaged this way. Please note that this position is not intended for permanent use.



The sensor may become hot during operation. Proper hand protection is recommended for maintenance work.



Do not dispose electrical and electronic equipment in household trash.

TECHNICAL SERVICE

Only use provided or approved equipment for operation. People other than authorized and approved electrical technicians shall NOT attempt to connect the device to a power supply or other controllers, as there is a risk of electrical shock by unsafe handling of the power source.

Do not attempt to service or repair this device:

- No user-maintainable parts are contained in the device.
- To avoid electrical shock, do not remove or open the cover.
- Unauthorized opening will void all warranties.
- smartmicro is not liable for any damages or harms caused by unauthorized attempts to open or repair the device.

RADIATION

This product has been tested and found to comply with Part 15 Subpart C of the Federal Communications Commission (FCC) or the European RED directive, or other national rules, depending on the country where it may be in use.

Operation is subject to the following two conditions:

- This device may not cause harmful interference.
- This device must accept any interference received, including interference that may cause undesired operation.

This device generates radio frequency energy. There are strict limits on continuous emission power levels to provide reasonable protection against harmful interference when the equipment is operated in a commercial environment.

- Human exposure to transmitted waves from this device is generally considered as safe. Still, it is considered good practice that humans are not subject to higher radiation levels than necessary.

This device may interfere with other devices using the same frequency band.

2 SENSOR SPECIFICATIONS

UMRR-11 Type 132 is a 77GHz radar sensor for altimeter applications. The Type 132 antenna aims at long range and a narrow field of view. The sensor features a medium-range-mode and a long-range-mode.

The sensor will cyclically output data according to the DroneCAN communication protocol. The sensor is operated as a “Range Finder” device.

2.1 MOUNTING POSITION

For optimal performance, the antenna of the radar should be parallel to the surface of the earth during normal flight. The antenna is located directly behind the black plastic radome, so the black plastic surface should always be facing down, see Figure 1.

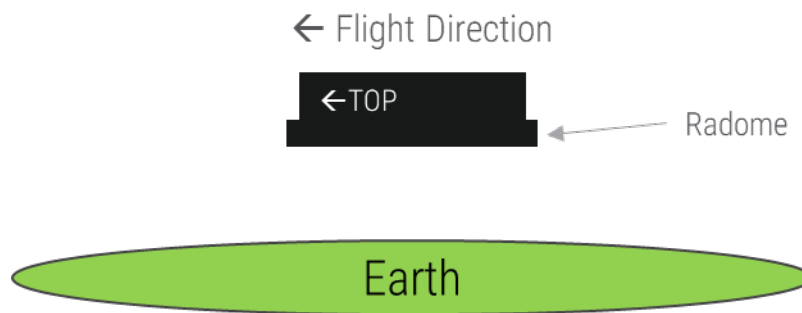

Figure 1: Mounting orientation of the sensor

The word „TOP“ on the sensor label and the accompanying arrow should either point in the direction of flight or directly opposite the direction of flight. Please ensure, that the arrow never points perpendicular to the flight direction.

The sensor may be mounted behind flat plastics surfaces, e.g. inside the fuselage, if this surface is radar transparent. Most plastic materials are radar transparent. If the fuselage contains carbon, epoxy resin or metal, it will likely absorb the radar signal so the radar will be unable to see through it.

2.2 SENSOR DIMENSIONS

All values are given in mm.

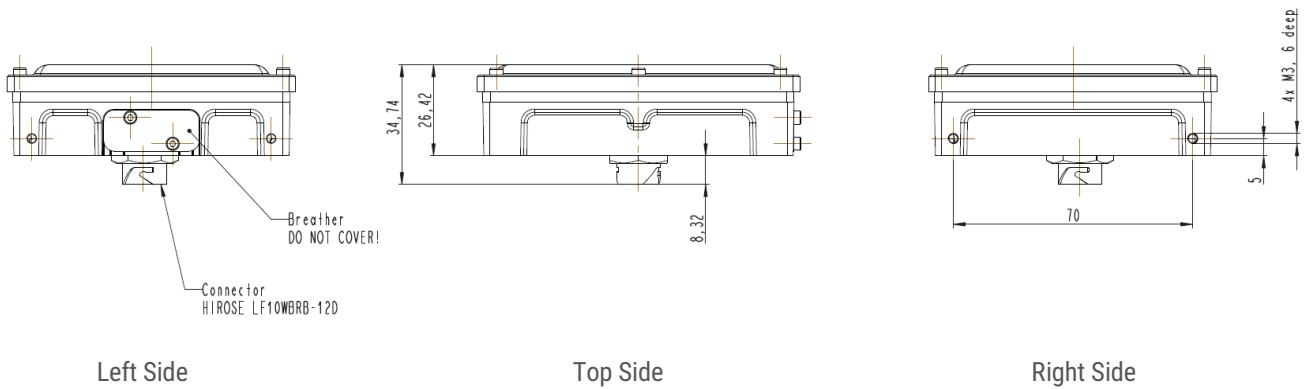
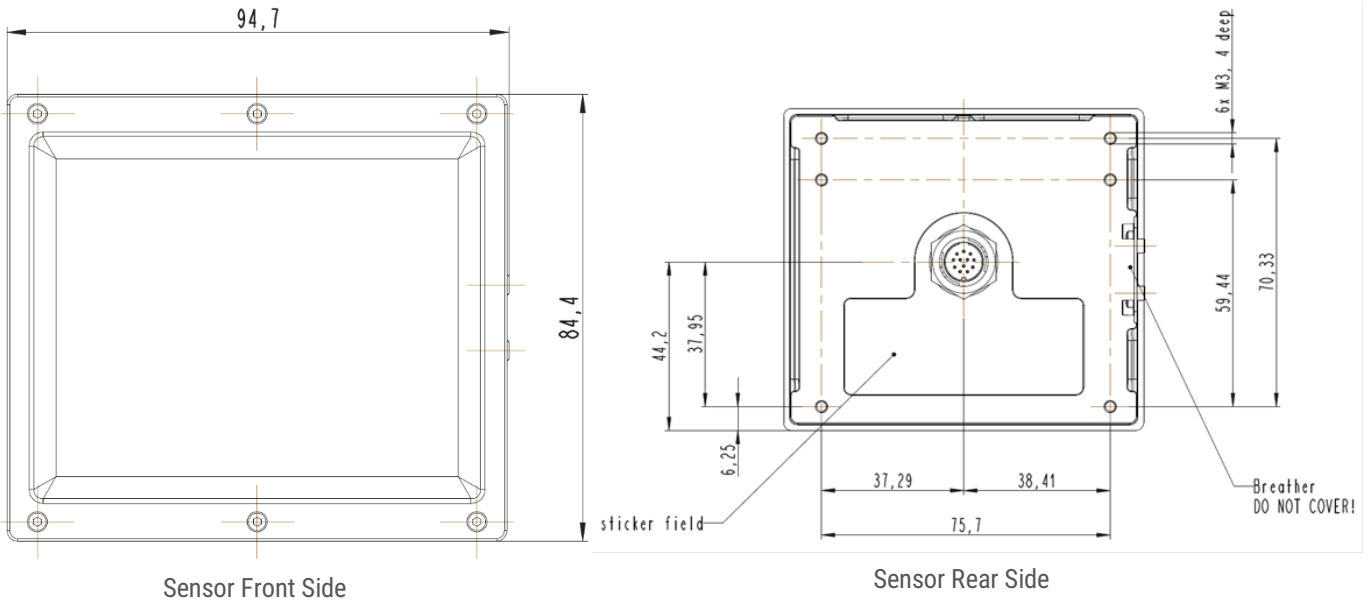

2.3 SENSOR CONNECTOR

The sensor connector is a 12-pin male (plug) circular bayonet type connector (waterproof IP67, series LF10WBRB-12PD, manufacturer Hirose, Japan). A female counterpart (socket), e.g. LF10WBP-12S, must be used to connect with the sensor.

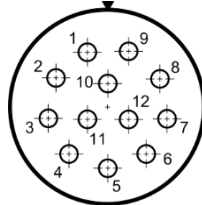

View on solder cup side of socket showing the pin numbering (rear view of female counterpart to be connected to sensor)

Sensor connector pin out model giving pin descriptions:

Pin No.	Function	Wire Color (MEDI type #KU110C12J002)
1	Sensor Ethernet TX H	Gray / red
2	Sensor Ethernet TX L	Red / blue
3	Sensor RS485 RX L	Pink
4	Sensor RS485 RX H	Gray
5	Sensor RS485 TX L	Brown
6	Sensor RS485 TX H	White
7	Sensor_GND	Blue
8	Sensor_Vcc	Red
9	Sensor Ethernet RX L	Black
10	Sensor Ethernet RX H	Purple
11	CAN H	Green
12	CAN L	Yellow

Please note that in the standard configuration the sensor does have a 120 Ohms resistor on board (CAN bus termination between CAN L and CAN H). If required, please contact smartmicro for a special product version with removed CAN resistor.

Several cable sets for initial operation and test purposes are offered by smartmicro, to deliver a fast set-up of a sensor system. Among those preconfigured ready-to-run cables as well as cable stumps (pig tail cables or various lengths) which carry the connector on one side and open wires on the other.

2.4 SENSOR AND HARDWARE IDENTIFICATION

The sensor housing is tagged with a type sticker containing the product description and the serial number. It also indicates which side of the sensor is the top side.

Sticker example:

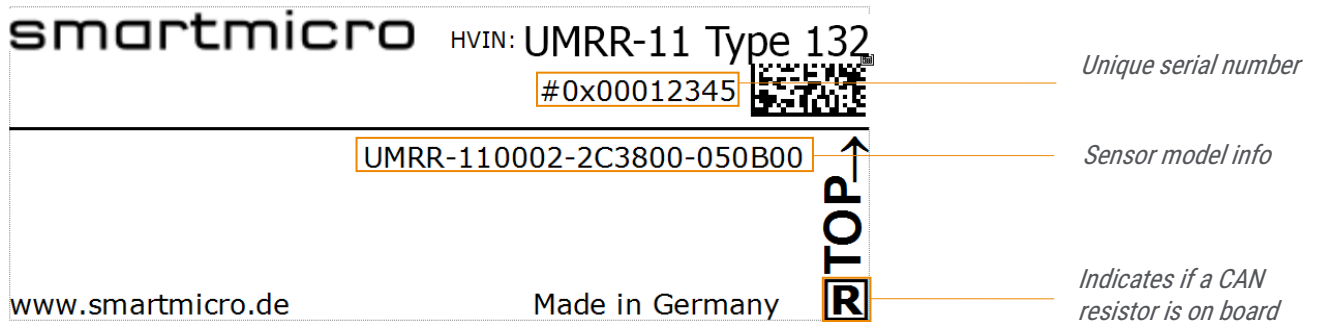

Additionally, the DSP board and the RF board have their own unique serial numbers.

3 GENERAL PERFORMANCE DATA

Parameter		Long-Range Mode	Medium-Range Mode
Operating Frequency		76...77GHz 4 center frequencies (bands)	76...77GHz 2 center frequencies (bands)
Range	Min./Max. ¹	1.0m/175m 3ft/574ft	0.5m/64m 1.6ft/210ft
	Separation	≤ 1.8m ≤ 5.9ft	< 0.66m < 2.17ft
	Accuracy	< 0.5m < 1.64ft or 1% (bigger of)	< 0.25m < 0.82ft or 1% (bigger of)
Speed	Min./Max.	-400...+200km/h -248...+124mph	-340...+170km/h -211...+105mph
	Separation	< 0.26m/s	< 0.26m/s
	Accuracy	≤ 0.1m/s	≤ 0.1m/s
Angle	Field of View: Azimuth ^{2,3}	-16...+16° (narrow beam)	-16...+16° (narrow beam)
	Field of View: Elevation ^{2,4}	-7.5...+7.5°	-7.5...+7.5°
Mechanical Details			
Weight		≤ 274g ≤ 9.67oz	
Dimensions (H/W/D)		94.7 x 84.4 x 26.4mm 3.7 x 3.3 x 1in (plus connector)	
Further Information			
Initialization Time		3s	
Update Cycle Time ⁵		≤ 55ms	
Operating Voltage ⁶		8...32V	
Power Consumption ⁷		3.75...5W	
Bandwidth		< 1000MHz	
Max. Transmit Power (EIRP)		< 35dBm	
Operating & Storage Temperature		-40...+85°C -40...+185°F	
Interfaces ⁸		1xCAN V2.0B (passive)	
Connector		Hirose LF10 series	
Shock / Vibration		100 g _{rms} / 14 g _{rms}	
Relative Humidity		0...95% (non-condensing)	
IP		67	
Pressure or Transport Altitude		0...10000m 0...32800ft	

¹ Typical values; all values given for bore sight; they may vary depending on the clutter environment. Please note that the radar system can neither achieve a detection probability of 100% nor a false alarm rate equal to zero.

² The total field of view is an angle interval in which reflectors can be detected; 3dB field of view is narrower.

³ Azimuth is perpendicular to flight direction.

⁴ Elevation is in flight direction.

⁵ Typical value; may be longer depending on the number of detected radar targets.

⁶ Measured at the connector.

⁷ Depending on supply voltage and temperature; power consumption increases with supply voltage and with temperature.

⁸ It is recommended to use an external surge protection for power, CAN, RS485, Ethernet and other interface ports.

3.1 START-UP TIME

After powering up or resetting, sensor readings meet the specified performance in 3s.

3.2 COMMUNICATION PROTOCOL

The sensor communicates via CAN V2.0B connection at a speed of 1Mbit/s using the DroneCAN protocol with 29-bit identifiers.

The sensor works plug-and-play with PX4 and Ardupilot based systems.

Please refer to the user manual for more detailed information on the implementation of the protocol.

Additionally, to the DroneCAN communication the sensor offers access to parameters, diagnosis and firmware download. This happens via proprietary Smartmicro communication protocols and is not required for Altimeter operation.

3.3 ALTIMETER OPERATION

Within the following figure the shows the representation in the “DroneCAN GUI Tool”. The four leftmost bytes of the UID reflects the sensor serial number. Software and Hardware version are shown as well.

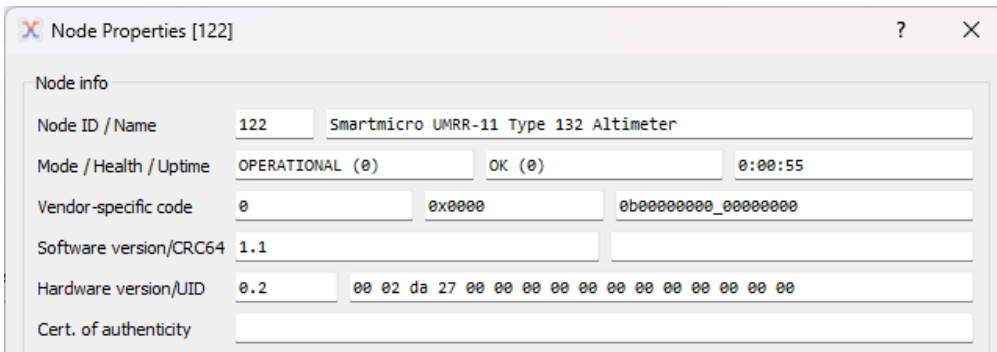

Figure 2: Sensor visualization in DroneCAN GUI Tool

While operating, the sensor sends the current altitude information and status with a fixed cycle time of 55 milliseconds or a telemetry rate of 18.2 updates per second.

See screenshots below: if an altitude could be detected, the “reading_type” is set to “VALID_RANGE”. Otherwise, the “reading_type” is set to “UNDEFINED” and a range value of “-1”.

The situations “too high” and “too low” are also reported as “UNDEFINED”.

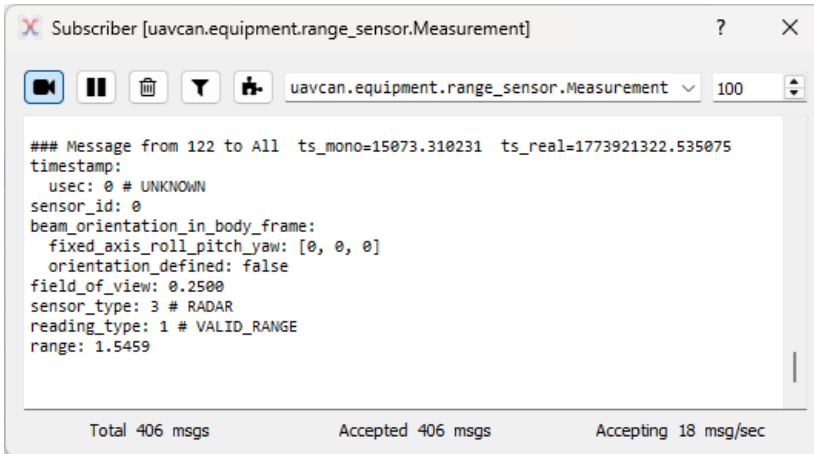

Figure 3: Valid altitude detected

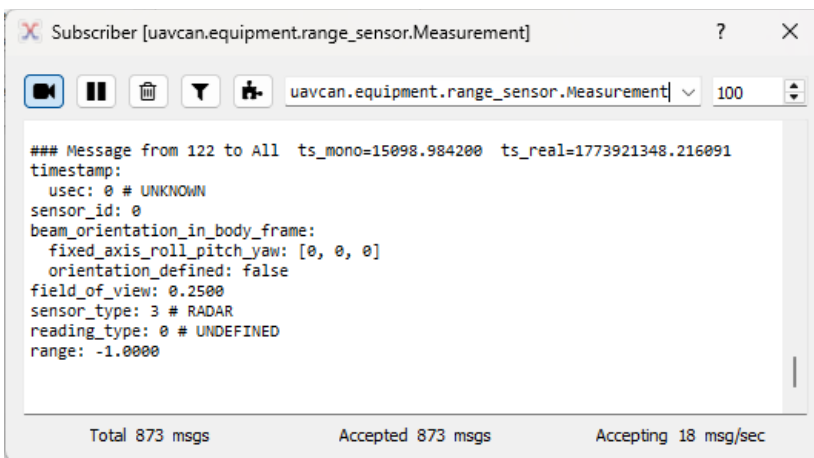

Figure 4: Altitude unknown

3.4 AUTOMATIC MODE SELECTION

The sensor supports a Long-Range and a Medium-Range mode. The selection of the mode happens automatically. This way, consistent altitude detection between 2 and 175 meters above ground is provided. Below 2 meters, the detection performance depends on the reflectivity of the surface.

3.5 PITCH/ROLL

The measured altitude is perpendicular to the radome of the sensor. When the vehicle rolls or pitches, the measured altitude is too high and must be compensated by roll and pitch angles.

4 ATTRIBUTIONS

The sensor firmware includes "libcanard", (<https://github.com/dronecan/libcanard>), under the MIT license (<https://opensource.org/license/mit/>).

5 COMPLIANCES

The sensor model complies with the following EU directives:

- RED 2014/53/EU
- RoHS 2011/65/EU
- EC 1907/2006 REACH

Applied Standards:

- Spectrum Usage:
 - EN 301 091-1 V2.1.1
 - EN 301 091-2 V2.1.1
- EMC:
 - EN 301 489-1 V2.2.0
 - EN 301 489-51 V2.1.0
- Health and Safety:
 - EN 62311: 2008
 - EN 62368-1: 2014 + AC: 2015

Regarding spectrum usage, this sensor model was tested and certified by independent test labs (formally approved by a test lab or notified body):

- EU RED directive
- FCC part 95M
- ISED RSS-251

This sensor model is also generally compliant with the following regional regulations (but may not be formally tested/approved):

- SRRC
- KCC
- MIIT
- NCC

Note: This statement of compliance means that the sensor allows operation compliant to the listed standards. However, not all standards are certified through test labs. Formal frequency approval or registration is not accomplished for all countries. In certain countries or regions, a customer-specific local frequency approval is reasonable. smartmicro supports customers throughout this process.

This device is NOT compliant to ISO IEC62443, to the EU CRA or similar international regulations. This device features an Ethernet port and/or WIFI connectivity. It is explicitly NOT INTENDED to be connected to the Internet or any other, unprotected network. The built-in connectivity is intended to be used exclusively for on-site use, or for use in a protected, proprietary user network. The user remains in charge to comply with any cyber-security and related regulations to protect the device from misuse on-site and in the user's network.

6 LEGAL DISCLAIMER NOTICE

All products, product specifications and data in this document may be subject to change without notice to improve reliability, function or otherwise.

Not all products and/or product features may be available in all countries and regions. For legal reasons features may be deleted from products or smartmicro may refuse to offer products. Statements, technical information and recommendations contained herein are believed to be accurate as of the stated date. smartmicro disclaims any and all liability for any errors, inaccuracies or incompleteness contained in this document or in any other disclosure relating to the product.

To the extent permitted by applicable law, smartmicro disclaims (i) any and all liability arising out of the application or use of the product or the data contained herein, (ii) any and all liability of damages exceeding direct damages, including - without limitation - indirect, consequential or incidental damages, and (iii) any and all implied warranties, including warranties of the suitability of the product for particular purposes.

Statements regarding the suitability of products for certain types of applications are based on smartmicro's knowledge of typical requirements that are often placed on smartmicro products in generic/general applications. Statements about the suitability of products for a particular/specific application, however, are not binding. It is the customer's/user's responsibility to validate that the product with the specifications described is suitable for use in the particular/specific application. Parameters and the performance of products may deviate from statements made herein due to particular/specific applications and/or surroundings. Therefore, it is important that the customer/user has thoroughly tested the products and has understood the performance and limitations of the products before installing them for final applications or before their commercialization. Although products are well optimized to be used for the intended applications stated, it must also be understood by the customer/user that the detection probability may not be 100% and that the false alarm rate may not be zero.

The information provided, relates only to the specifically designated product and may not be applicable when the product is used in combination with other materials or in any process not defined herein. All operating parameters, including typical parameters, must be validated for each application by the customer's/user's technical experts. Customers using or selling smartmicro products for use in an application which is not expressly indicated do so at their own risk.

This document does not expand or otherwise modify smartmicro's terms and conditions of purchase, including but not being limited to the warranty. Except as expressly indicated in writing by smartmicro, the products are not designed for use in medical, life-saving or life-sustaining applications or for any other application in which the failure of the product could result in personal injury or death.

No license, expressed or implied, by estoppel or otherwise, to any intellectual property rights is granted by this document or by any conduct of smartmicro. Product names and markings noted herein may be trademarks of their respective owners.

Please note that the application of the product may be subject to standards or other regulations that may vary from country to country. smartmicro does not guarantee that the use of products in the applications described herein will comply with such regulations in any country. It is the customer's/user's responsibility to ensure that the use and incorporation of products comply with regulatory requirements of their markets.

If any provision of this disclaimer is, or is found to be, void or unenforceable under applicable law, it will not affect the validity or enforceability of the other provisions of this disclaimer.